

# SMX-6™ Automatic Mixer

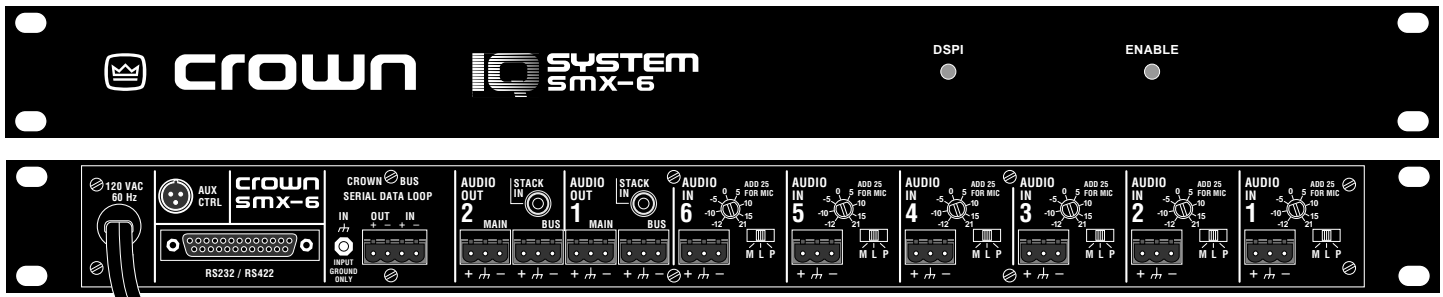

**SMX-6 SENSING MIXER**  
(Front Panel shown above, Rear Panel shown below)

## OVERVIEW

### What is an SMX-6?

The SMX-6 is a single rack space six by two automatic mixer designed to be configured with a computer and appropriate software. Once initially setup the computer becomes optional. The key to the ability of the SMX-6 operating as a stand alone automatic mixer is distributed intelligence™. In an IQ System the brains of the system live out in the system. This means the audio system is not going to be lost even if the computer or communication cables fail. Due to the modular nature of the SMX-6, multiple units also may be used together to form a wider or deeper automated mixer.

## HARDWARE BLOCK DIAGRAM

Refer to the pictures of the front and rear panels shown above and the block diagram of the SMX-6 mixer on Page 2.

### Audio Main Inputs:

Six balanced inputs with removable 3 pin barrier block. The preamp stage includes:

- M/L/P switches set each input to line level (L) with 0 dB gain, mic level (M) with 25 dB additional gain, or phantom (P) which is 25 dB additional gain and +44 VDC phantom power.
- A trim pot at each input allows for prefade gain adjustment of -12 dB to +21 dB gain after the M/L/P switch.

Prefade sensors at the output of each preamp stage sense input audio level just before the input signal is delivered to the processor controlled VCAs. There are two VCAs under processor control

at the output of each sensor. One VCA controls the gain from input to output mix 1 and the other VCA controls gain from the input to output mix 2. The net result is 12 VCAs total, six per output mix.

### Audio Stack Inputs:

Two inputs, one per output mix. Connections are via unbalanced RCA phono jacks. These inputs are op-amp isolated. There is no processor control of audio coming into these inputs. The purpose of the stack inputs is to allow construction of a wide mixer with more than six inputs by taking the outputs of one mixer and going into the stack inputs of a second mixer. This means that main inputs do not have to be used to expand the effective size of the overall mixer.

### Audio Main Outputs:

There are two summing buses. Each summing bus provides the output mix for the corresponding output channel. Op-amps buffer the summing bus to the output connection and balance the audio output. The outputs are via 3 pin removable barrier blocks.

### Audio Bus Outputs:

In addition to the two main outputs, there are also two bus outputs. Bus outputs 1 and 2 provide the same audio output as main outputs 1 and 2. Op-amps buffer the summing bus to the output connection and balance the audio output. What makes the Bus Outputs different are relays under processor control which may be used to turn on or off the Bus Output drive. 3 Pin removable barrier blocks are used.

### Aux Port:

The unit is equipped with a TB-3M type

mini-XLR port. This port may be used to provide a control signal or sense a control signal.

- Pin 1 is ground reference
- Pin 2 is output under processor control. When on it provides 10 VDC at 16 ma. When off it is open collector (high impedance).
- Pin 3 is sensing input. +5 to +30 VDC is sensed as a logic high. The circuit floats, therefore tie to ground or TTL source for definite high or low.

### Indicators:

A Power light on the front panel indicates the unit is plugged into AC mains and AC power is available. A DSP1 data signal presence indicator lights to indicate communication or may be forced on via processor control.

### Crown Bus Port:

The Crown Bus is a serial data loop where components are connected into the loop and one component serves as system interface for all. This unit may serve as a system interface or may simply operate as a component on a Crown Bus data loop. Although the Crown Bus may function on a variety of media, Crown uses a two-wire 20 ma current loop for input and output Crown Bus connections. On this unit connections are made via 4 pin removable barrier block. Even if the unit is communicating directly with a PC via its serial port, it always functions in software as an addressable component on a Crown Bus loop. The unit must have a valid loop address. A valid address is:

- 1 to 250 set via 8 segment DIP switch
- No other SMX on the same Crown Bus data loop may have the same address.

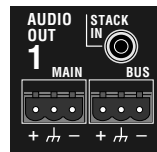
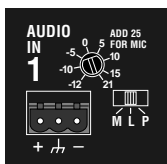

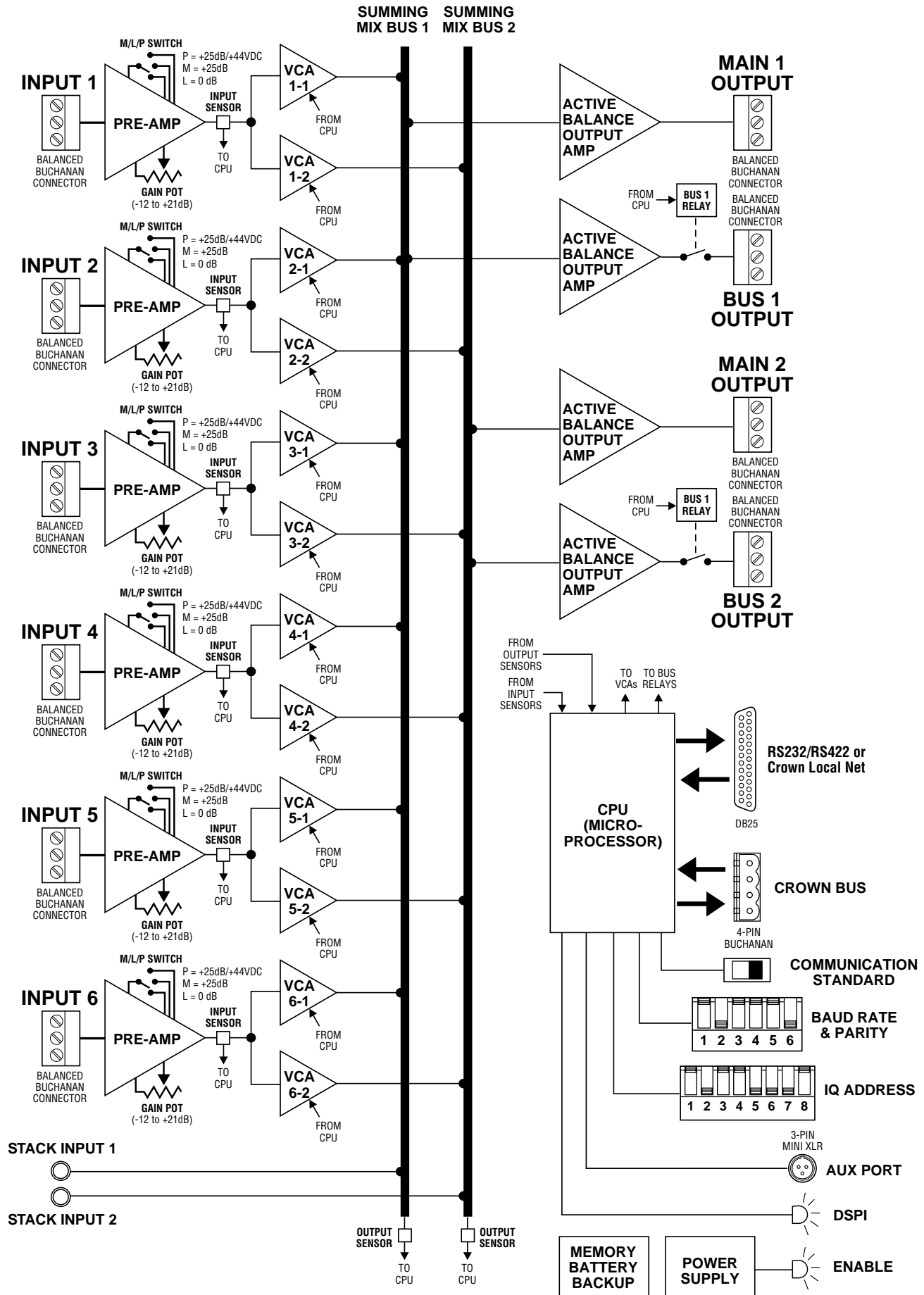

**SMX-6 Basic Block Diagram (Page 2 of 5)**

**SMX-6 Automatic Mixer (Page 3 of 5)**

The Crown Bus is asynchronous with 8 data bits, 1 start bit, 1 stop bit, no parity, and operates at 38400 baud. The SMX is not a U-Code protocol component.

**Serial Port:**

The serial port on this unit is a female 25 pin D-Shell. RS232 and RS422 are supported with 8 Data bits, 1 start bit, 1 stop bit, no parity. Up to 19200 baud supported. The serial port for the SMX may be used for direct communication with a PC such that the SMX serves as interface:

- May serve as interface for up to 20 components connected to the Crown Bus.
- Components supported include other SMX units, AMB-5 mixers, MPX-6 mixers, PIP-AP, PIP-APM, PIP-APS, all MRX matrixers, and the White 4700 Series EQ.
- No support for U-Code protocol.

An alternative use for the serial port on an SMX is the Crown Local Net (CLN). CLN is a special operational mode that would be used to build a wide automatic mixer (two or more SMX units interconnected) where system wide gate count

or priority structure control is required. CLN involves a pseudo RS422 wiring interconnection between SMX units. When an SMX is placed in CLN mode from within software the serial port may then be used for CLN and only CLN (interface capabilities are removed. To configure SMX units for CLN a different type of component must serve as system interface.

**Setup Switches:**

- The IQ Address is set by an 8 segment DIP switch. Valid address values are 1 to 250 (0 and 251-255 are reserved for system usage).
- RS232/422 Standard switch must be configured appropriately for use of the serial port.
- Baud is adjustable via DIP switch up to 19200. This setting must be configured properly for use of the serial port.
- Parity is set ON or OFF and ODD or EVEN via DIP switch. Normally set to OFF, this setting only applies to use of the serial port.

**Memory Backup:**

The unit is equipped with a rechargeable battery. The unit has 60 day memory backup on full charge.

**COMPUTERIZED FEATURES**

**Monitoring:**

Input audio level monitoring has a range of -40 to +25 dB. Input level is sensed between the preamp and VCAs for a total of 6 sensors, one per input. The output audio level is sensed at each output mix bus with a range of -40 to +25 dB.

**DSPI:**

The Data Signal Presence Indicator (DSPI) light on the front panel flashes to indicate data traffic addressed to or from the unit. This light may be forced on from software.

**Aux Port:**

The aux port on the mixer is used to send or receive a control voltage. From software you may turn the aux output on or off. IQ software is also able to sense the status of the aux input and is capable of taking independent action based on a sensed input.

**Bus Output Relays:**

Audio bus outputs are identical to their respective main outputs in every way except for the addition of software controlled isolation relays.

**VCA Gain Control:**

The heart of the SMX is its functionality as a mixer. Each input may be routed to either or both outputs by VCAs under processor control. The processor may, in turn, be set up to control VCAs using on board automatic intelligence or may be controlled in real time manually from software. The VCAs offer a control range of -100 to +25 dB.

**MANUAL MIXING IN REAL TIME**

All setup for manual or automatic operation is accomplished, at least initially, with IQ software from a PC. The SMX has a software switch that puts the unit into a manual mode or an automatic mode. When in manual mode you may make changes from software that affect VCA gain in real time. Gain may also be manipulated in real time from alternate control devices such as a Drone or a third party control device (Ex. AMX, Crestron, Interface Controls, etc.). Once VCA gains are set from the PC (or control device) the processor maintains that gain structure until it receives an instruction to change. In the manual mode the automatic features such as compress-

**SMX-6 Manual or Automatic Operation**

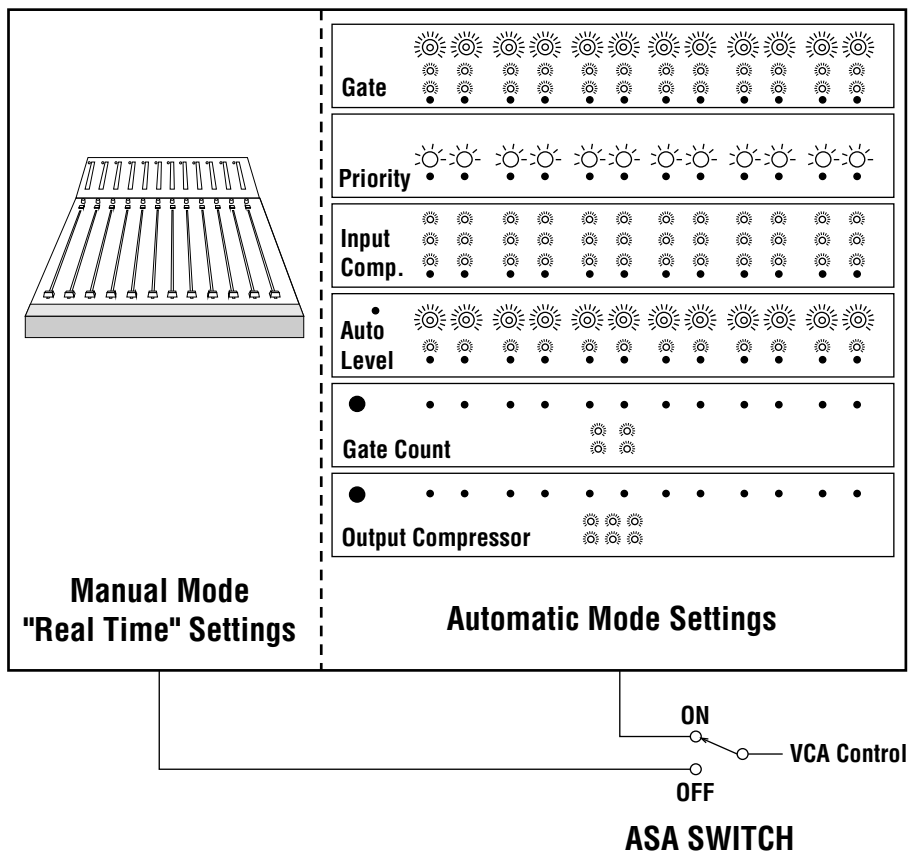

## SMX-6 Automatic Mixer (Page 4 of 5)

sors are disabled. Functions other than VCA gain control (Bus relays, DSPI, and aux output controls) are only controlled manually.

### AUTOMATIC MIXING

#### Feature Set:

To make use of the automatic mixing power of the SMX-6 the unit must be configured with IQ software. Once the unit is placed in automatic mode and its intelligence is fully configured, the unit will mix without further outside communication being necessary. Intelligence is programmable independently for each VCA. Features making up the total mixing algorithm are comprised of user defined variables set in software. These features, also called algos, include:

- **Max Gain**
- **Input Noise Gate**
- **Duck Priority**
- **Input Compressor**
- **Auto Level**
- **Output Compressor**
- **Gate Count**
- **Max Number of Open Mics**
- **Crown Local Net**

#### Max Gain

The purpose of Max is to prevent feedback and provide a safety limit. Max Gain is defined as the maximum gain of the VCA regardless of interaction with other algos any time an input is gated on, or if the gate function is not used. Max Gain may be set -100 to +25 dB Gain for each VCA. Two global settings are used to tie Max Gain to the manual gain controls. These are Max Gain Tracks Control Block and Control Block Override. These are two switches which are used, usually together, to allow for smooth operational control of Max Gain for semi-automatic operation. The need for this mode of operation may arise when using third party control system products or some types of IQ controls.

#### Input Noise Gate

The purpose of a noise gate is to attenuate an input when little or no input signal is present. With the SMX-6 you configure various parameters which define the precise operation of the gating feature at each input. Several other automatic features also depend on proper operation of the gating function. Parameters involved are:

- Gate is an ON/OFF switch to enable or disable this feature for each VCA.
- Threshold is a parameter that sets the input level required to gate on for each VCA. The range is -100 to +25 dB sensed.
- Low Set is a parameter that sets the gain of the VCA when the input is gated off. The range is -100 to +25 dB gain.
- Delay Time is the time delay in seconds after the input level drops below *Threshold* until the VCA actually gates off. The range is 0.2 to 30 seconds.

#### Duck Priority

The duck priority feature allows the mixer to have a priority structure of up to six levels. Each output channel may have a different priority structure. Parameters involved are:

- Duck priority is an ON/OFF switch tells each VCA whether or not they participate in the priority structure.
- Priority level is a setting from 1 to 6 where 1 = highest and 6 = lowest priority. Each VCA is set independently.

#### Input Compressor

The SMX-6 mixer is equipped with both input compressor and an output compressor features. The input compressor differs from a conventional compressor due to its feed forward structure. This feed forward technology prevents "breathing" and virtually eliminates "pumping." The parameters for the input compressor are:

- Compressor is the ON/OFF switch for each VCA.
- Threshold is the sensed input level above which the compressor begins to actuate. The range is -100 to +25 dB and is set at each VCA.
- Ratio may be set to 1:1, 2:1, 4:1, 8:1, 16:1, 32:1 or ∞:1 for each VCA.
- Release Time is the time in seconds to release compression at a slope of seconds per 10 dB. The range is 0.2 to 30 seconds for each VCA.
- Attack Time is a global setting for all VCAs and may be set to fast or slow depending on your preference.

#### Auto Level

The auto level feature of this unit is de-

signed to handle long term input level variations to maintain a consistent output level. This is basically done by selecting a desired average output level then setting up the other parameters to define the response. Parameters include:

- Auto Level is an ON/OFF switch that enables or disables the auto level function for each VCA.
- DAOL (Desired Average Output Level) is the target output level you set. Once the auto level function is working the VCA raises or lowers gain as necessary to achieve the DAOL given the sensed input level. The DAOL setting range is -100 to +25 dB.
- Reaction Time is the time in seconds to change gain 10 dB toward the necessary gain structure to obtain the DAOL. The range is 0.2 to 30 seconds.
- Idle Gain is the gain that the VCA goes to when the input initially gates on. In other words it is the starting point. Used in conjunction with other features this parameter can afford the mixer a variety of complex effects such as ramping in of background music.
- Auto Level Gate Function is a global setting that may be set to Open To Idle Gain or Open To Last Position. When set to Open To Idle Gain an input will initially gate on to the Idle Gain setting and the auto level feature will take over from there. The advantage to this setting is that it allows for ramping and input gain is the same every time a gate first comes on. When set to Open To Last Position the auto level feature remembers the gain of the VCA at the time the input last gated off so that gain goes back to that level the next time that the gate opens again.

#### Output Compressor

The SMX output compressor is different that a conventional output compressor because you can actually choose which inputs participate in output compression. This can be a valuable tool if you have microphones on some inputs and a playback source on other inputs. You might reasonably expect that the playback source such as a CD or tape player

## SMX-6 Automatic Mixer (Page 5 of 5)

will not output level which would require compression, so you might not configure those inputs to participate in the output compression scheme. Output compressor parameters are primarily per output rather than input and include:

- **Compressor** is a master ON/OFF switch for each output that enables or disables output compression for that output.
- **Limiters** is an ON/OFF switch for each VCA that configures which inputs may participate in output compression.
- **Threshold** is the sensed output level above which the compressor begins to actuate. The range is -100 to +25 dB and is set per output.
- **Ratio** may be set to 1:1, 2:1, 4:1, 8:1, 16:1, 32:1 or ∞:1 for each output.
- **Release Time** is the time in seconds to release compression at a slope of seconds per 10 dB. The range is 0.2 to 30 seconds for each output.

### Gate Count

The gate count feature attenuates all gated on inputs when more than one input is gated on by a predetermined amount. The purpose of this feature is to prevent feedback problems due to multiple open mics. Settings are per output channel. Parameters include:

- **Gate Count Master** is a global ON/OFF switch.
- **Gate Count** is a set of ON/OFF switches that dictates which VCAs participate in the gate count.
- **Amount** is how much attenuation per additional open mic. Each output is set within a range of 0.5 to 16 dB.

### Max Number of Open Mics

This feature is sometimes called a filibuster control because it can make the mixer work in a first come first served manner by limiting how many inputs may gate open simultaneously. The only parameter to set is the actual maximum number of open mics. The range is 1 to 6 with settings for each output.

### Crown Local Net

Crown Local Net (CLN) is a special mode of operation that is used when two or more SMX units are stacked together

to form a wide automatic mic mixer where system wide duck priority or gate count features are required. This involves both software and hardware setup and it also requires that the serial port of each mixer be dedicated to CLN use. Note that if an SMX mixer is going to be used on a CLN that the SMX can not be used as a system interface. Due to the number of steps and detail involved with setup of a CLN, please contact the Crown Technical Support Group if you are interested in more information on this feature.

## SYSTEM LEVEL INFORMATION

### Communication:

In an IQ System the basic communication structure is based on the premise that it must be able to support a PC being used with several IQ components. The computer is connected to the IQ System interface via RS232. The interface converts the protocol from RS232 to Crown Bus media and back again. In a small system or a single SMX system the SMX itself may serve as the system interface. The IQ-INT II, IQ-PSI, Drone, SMX-6, AMB-5 and MPX-6 are all components which may serve as a system interface for an SMX-6. The Crown Bus is a serial data loop carrier of IQ command protocol. Crown has implemented it as a two wire twisted pair current loop to allow for low cost long distance connections. For very long loops (over 1000 feet) data repeaters (IQ-RPT) or fiber optic cable may be used to connect equipment rooms that are some distance apart. The Crown Bus itself does not carry audio.

### U-Code Protocol:

U-Code is new form of IQ command protocol developed for enhanced new product and third party product development. At this time the SMX-6 firmware is not written in U-Code. Although it may be used in systems with U-Code products, the SMX-6 may not be used as system interface for U-Code products.

### Software:

Several IQ Software packages are available to communicate with an SMX-6. Each unit is shipped with basic DOS software which allows you to communicate with the SMX-6, AMB-5, MPX-6, and MRX Matrixer units. More advanced

software includes the Turbo or Sys-Config software packages. Turbo is a DOS program that includes powerful graphics support and support of the full IQ product line. Sys-Config is an advanced package which has security, scheduling, alert reporting, and other powerful features plus the power of Turbo built in.

### PC Requirements:

The computer you select for use with your IQ System is very important. Exact minimum requirement vary depending on the software package being used, but for the more advanced software your machine should at least be a 486SX/33 with the following: 4 MB RAM, 16550 UART for the com port used by IQ, DOS 6.2, Mouse (with DOS driver, third button features supported). In most cases Turbo software will operate as a DOS application from Windows,® including Windows 95.®

## SPECIFICATIONS

Maximum Input Level (Mic): +7 dBu.

Maximum Input Level (Line): +32 dBu.

Phantom Power: +44 VDC.

AC Power: 120/240 VAC 50/60 Hz.

Common Mode Rejection: 55 dB: 60 to 1 kHz typical; 45 dB: 20 to 20 kHz.

Frequency Response: +0/-1 dB, 20 to 20 kHz.  
THD: <0.05% at +4 dBm output; <0.15% at +20 dBm output 20 to 20 kHz measured at mic input with 40 dB gain.

Noise: Output noise all inputs off is -80dBu (106 dB below rated output); output noise with one line input at 0 dB is 80 dB; equivalent input noise at mic input with 46 dB of gain and 150 ohm source is -125 dBu. Note that noise specs are typical, unweighted, and 20 to 20 kHz.

Crosstalk: Adjacent inputs/outputs at 1 kHz better than -80 dB; adjacent inputs/outputs 20 to 20 kHz better than -65 dB.

## Guaranteed Excellence



Crown International, Inc.  
Professional Audio Division  
PO Box 1000

Elkhart, IN 46515-1000  
Ph. 800-342-6939/219-294-8200  
Fax. 219-294-8301

### Trademark Notice:

*Algo*,™ *Distributed Intelligence*,™ and *SMX-6*™ are trademarks, *Crown*® and *IQ System*® are registered trademarks of Crown International Inc.