

# Operation Manual

## ComTech D Series Power Amplifier



CTD-2125

CTD-4125

CTD-8125

**Product Registration:** Register your new product at [www.warranty.harmanpro.com](http://www.warranty.harmanpro.com).

**Obtaining Other Language Versions:** To obtain information in another language about the use of this product, please contact your local Crown Distributor. If you need assistance locating your local distributor, please visit [www.crownaudio.com](http://www.crownaudio.com).

This manual does not include all the details of design, production, or variations of the equipment. Nor does it cover every possible situation which may arise during installation, operation, or maintenance.

The information provided in this manual was deemed accurate as of the publication date. However, updates to this information may have occurred. To obtain the latest version of this manual, please visit the Crown website at [www.crownaudio.com](http://www.crownaudio.com).

**Trademark Notice:** Com-Tech, BCA, Crown, Crown Audio, Amcron and Multi-Mode are registered trademarks of Crown International. DriveCore, DriveCore Install, IQwic, PIP and PIP2 are trademarks of Crown International. Other trademarks are the property of their respective owners.

**Some models may be exported under the name Amcron®**

© 2026 by HARMAN International®, Inc. 8500 Balboa Blvd. Northridge, CA 91329

## Table of Content

<b>Table of Content .....</b>	<b>2</b>	<b>WebUI – Using Pilot Tone and Load Monitoring .....</b>	<b>33</b>
<b>Welcome .....</b>	<b>3</b>	Configuring Incoming Pilot Tone Monitoring .....	33
Features .....	3	Configuring Output Load Monitoring .....	34
How to Use This Manual .....	3	Generator .....	34
<b>Installing the Amp .....</b>	<b>4</b>	Load Monitor .....	34
Unpacking .....	4	<b>WebUI – Dante Output Patching .....</b>	<b>35</b>
What’s in the box .....	4	<b>WebUI – Hamburger Menu .....</b>	<b>36</b>
Installing the Mounting Accessories .....	5	Using GPIO Control Port .....	36
Additional Materials .....	7	Hardware Specification .....	36
Installing the Amplifier .....	7	Connecting BSS AC-V and AC-5S .....	37
Proper Cooling .....	7	Configuring the GPI Control Port .....	37
<b>Front Panel Overview .....</b>	<b>8</b>	Configuring the Relay Output Control Port .....	39
<b>Rear Panel Overview .....</b>	<b>9</b>	Using System Settings .....	40
<b>Hardware Setup .....</b>	<b>10</b>	Setting up Access Contro.....	40
Connecting the Network Cable .....	10	Power and Fan Management .....	41
Connecting the AC Power Cord .....	10	Configuring the Network .....	41
Power Up Procedure .....	10	Using Device Setting .....	42
Precautions .....	11	Device information .....	42
Wiring Input Connectors .....	12	Firmware .....	42
Wiring Output Connectors .....	12	Speaker Tunings .....	42
<b>Installing the Software and Configuring the Network 13</b>		Factory Reset .....	42
Installing Manager Desktop .....	13	Using Export / Import (available in future FW release) .....	43
Launching Manager Desktop .....	13	Export .....	43
Device Configuration .....	14	Import .....	43
Network setting .....	14	<b>WebUI - Alert Page .....</b>	<b>44</b>
Firmware Update .....	15	Alerts .....	44
Reboot, Locate, Factory Reset & Launching WebUI (Web User Interface) .....	16	Line Integrity .....	44
<b>WebUI – Overview Page .....</b>	<b>17</b>	Clip and Limiter .....	44
Analog Input & Dante Input (READ ONLY) .....	17	Health Monitoring .....	44
Dante Output (READ ONLY) .....	17	Event Logs .....	44
Amplifier Output (EDITABLE) .....	18	Sequence (SEQ #) .....	44
Pilot Tone, Load, Priority, Force and Alert Monitoring .....	18	TIMESTAMP .....	44
Locate .....	19	EVENT .....	44
<b>WebUI – Configuring the Inputs and Outputs .....</b>	<b>20</b>	SEVERITY .....	45
Configuration Page .....	20	CATEGORY .....	45
Channel Naming .....	20	Clear Alerts / Logs .....	45
Switch between Analog Input and Dante Input .....	20	Refresh .....	45
Stereo Linking .....	20	Export .....	45
Configure the Inputs .....	21	<b>Application Examples .....</b>	<b>46</b>
Trim and Mute Control .....	21	Power Share across 2 channels .....	46
HPF (High Pass Filter) Control .....	21	Power Share across 4 channels .....	46
Configure the Outputs .....	22	Network Modes .....	47
Using Output Source Mixer Panel .....	22	<b>System Protection .....</b>	<b>50</b>
Parametric EQ Panel .....	23	<b>Troubleshooting .....</b>	<b>51</b>
Adjusting Room Delay .....	25	<b>Signal Path Block Diagram .....</b>	<b>53</b>
Configuring Output Mode .....	25	<b>Specification .....</b>	<b>54</b>
Speaker Tuning Panel .....	25	Dimension Drawings .....	56
Custom Speaker Tuning .....	26	<b>Warranty (United States Only) .....</b>	<b>57</b>
Output Level Panel .....	29	<b>Service .....</b>	<b>58</b>
<b>WebUI – Using the Scene Presets .....</b>	<b>30</b>	Worldwide Service .....	58
Managing the Scene Presets .....	31	US and Canada Service .....	58
Storing a Scene Preset .....	31	Service at a US or Canada Service Center .....	58
Importing a Scene Preset (available in future FW release) .....	31	Factory Service .....	58
Recalling a Scene Preset .....	31		
Updating a Scene Preset .....	31		
Renaming a Scene Preset .....	32		
Deleting a Scene Preset .....	32		
Exporting a Scene Preset (available in future FW release) .....	32		

## Welcome

Thank you for purchasing a Crown ComTech installation amplifier. The ComTech D Series amplifiers are designed, engineered, and manufactured to the industry's highest quality standards and offer system integrators with the advanced features and flexibility required for challenging 21st-century installed-sound applications. Versatile, compact, and highly energy-efficient, ComTech D Series amplifiers continue the unbroken Crown tradition of leadership in professional and commercial power amplifier technology.

## Features

- Dante digital network audio transport –via DEP (Dante Embedded Platform) Up to 8 x 8 Channels of digital audio over network
- Support configuration and control using WebUI
- Monitoring and control over TCP/IP
- Programmable GPIO (general purpose input/output) control port
- Digital signal processing (EQ Filters, crossover, delay, LevelMAX™ limiter)
- Support JBL® Speaker Tunings with FIR filter coefficients
- Custom speaker tunings
- Devices configuration file (import/export)
- 40 scenes presets
- 48kHz signal processing
- Power Sharing across multiple amplifier channels
- Power saving mode
- 70V/100V direct drive
- Each channel independently configurable for low Z or high Z operation
- Advance protection circuits
- Five years, no-fault transferable warranty –Your investment is fully protected
- Included speaker tuning for various JBL® speaker models

## How to Use This Manual

This manual provides the necessary information to safely and correctly setup and operate your Crown product. It does not cover every aspect of installation, setup, or operation that might occur under every condition. For additional information, please contact technical support, your system installer, or retailer.

We strongly recommend you read all instructions, warnings, and cautions contained in this manual. Also, for your protection, please register your product at [www.warranty.harmanpro.com](http://www.warranty.harmanpro.com). And save your bill of sale – it's your official proof of purchase.

If viewing this manual from a computer or mobile device that supports interactive PDFs, the Table of Contents, page references, figure references, and URLs are all interactive and can be clicked on or pressed to navigate to the corresponding page or web URL.

# Installing the Amp







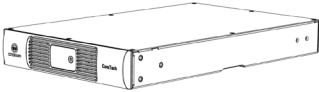
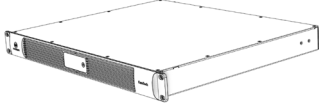
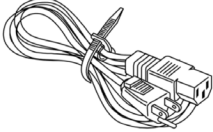

## Unpacking

Unpack your amplifier and inspect for any damage that may have occurred during transit. If damage is found, notify the shipping company immediately. Only you can initiate a claim for shipping damage, though Crown will be happy to help as needed. If the product arrived showing signs of damage, save the shipping carton for the shipper's inspection.

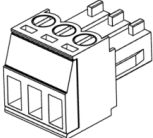
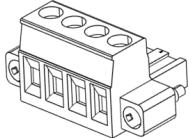
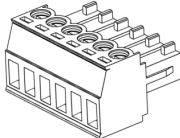
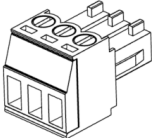
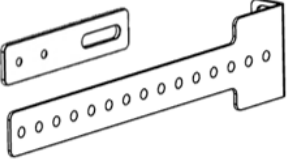
We also recommend that you save all packing materials for use if you ever need to transport the unit. Never ship the unit without the factory carton and packing materials.

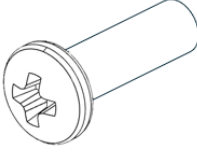
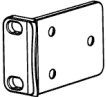
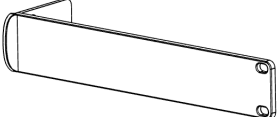
## What's in the box

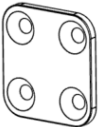
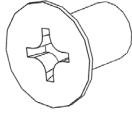
The items included the box varies on different models. See **Figure 1**.

 CTD-2125 (x1) CTD-4125 (x1)	 CTD-8125 (x1)	 <b>AC Power Cord</b> US & CN Version (x1) EK Version (x2) NP Version (N/A)	 <b>Quick Start Guide</b> CTD-2125 (x1) CTD-4125 (x1) CTD-8125 (x1)
 <b>Input Connector (GREEN)</b> CTD-2125 (x2) CTD-4125 (x4) CTD-8125 (x8)	 <b>Output Connector (GREEN)</b> CTD-2125 (x1) CTD-4125 (x2) CTD-8125 (x4)	 <b>GPI Connector (BLACK)</b> CTD-2125 (x1) CTD-4125 (x1) CTD-8125 (x2)	 <b>Fault Relay Connector (BLACK)</b> CTD-2125 (x1) CTD-4125 (x1) CTD-8125 (x1)
 <b>Rear Support</b> CTD-2125 (x1) CTD-4125 (x1) CTD-8125 (x2)	 <b>Rear Support Screws Type I</b> <b>M4x6 (Philips)</b> CTD-2125 (x2) CTD-4125 (x2) CTD-8125 (x4)	 <b>Rear Support Screws Type II</b> <b>10-32 0.75 (Philips)</b> CTD-2125 (x2) CTD-4125 (x2) CTD-8125 (x4)	
 <b>Rack Ear</b> CTD-2125 (x1) CTD-4125 (x1)	 <b>Half Rack Extension Ear</b> CTD-2125 (x1) CTD-4125 (x1)	 <b>Rack Ear Screws</b> <b>M5x8 (Philips)</b> CTD-2125 (x6) CTD-4125 (x6)	
 <b>Bottom Mounting Plate</b> CTD-2125 (x2) CTD-4125 (x2)	 <b>Bottom Mounting Plate Screw</b> <b>M4x6 (Philips)</b> CTD-2125 (x4) CTD-4125 (x4)	 <b>Rubber Feet</b> CTD-2125 (x4) CTD-4125 (x4)	

**Figure 1: What's in the Box**

## Installing the Mounting Accessories

### Rack Mounting One Half Rack Unit

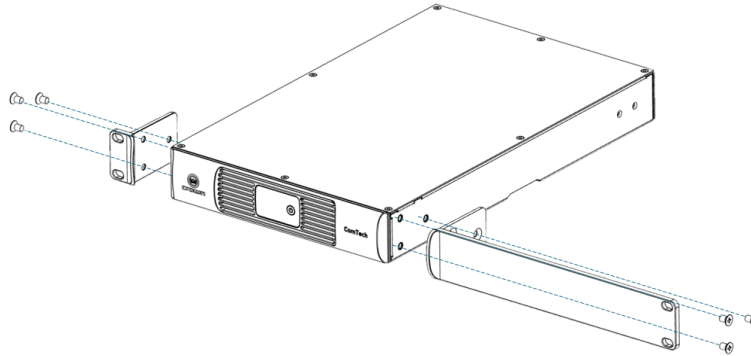
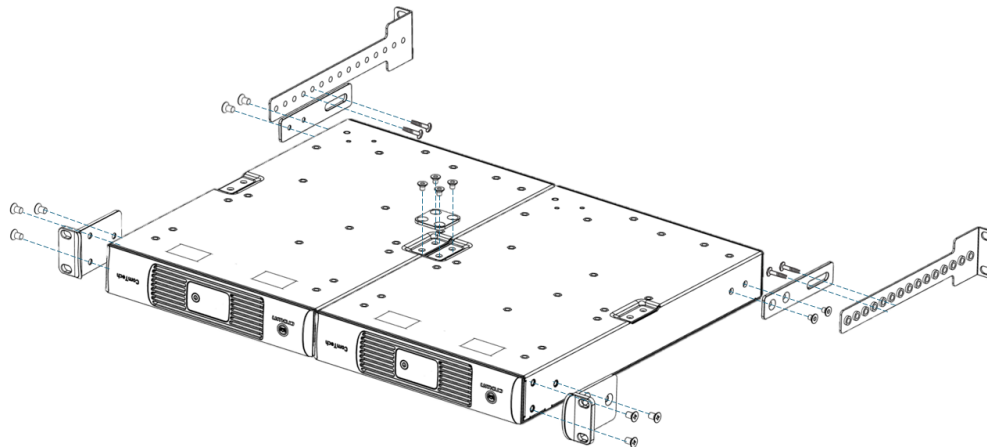

**Figure 2:** Rack Mounting Single Half Rack Unit

To install a single unit, refer to **Figure 2** and follow the steps below:

1. Determine which side of the rack opening will be used for the amplifier and attach the **Half Rack Extension Ear** to the other side at the front of the amplifier using the **(M5x8 Philips)** screws provided.
2. Attach one of the **Rack Ear** to the other side of the assembly, as shown in the diagram, with the **(M5x8 Philips)** screws provided.
3. Install the assembly into the cabinet using the rack mount screws through the **Rack Ears**. For details of installation in the chassis of the cabinet, refer to the user guide of your cabinet.

### Rack Mounting Two Half Rack Unit



**Figure 3:** Rack Mounting Two Half Rack Units

To install two units in your cabinet system, refer to **Figure 3** and follow the steps below:

1. Align two modules side by side and upside down with the front panel towards the same direction.
2. Connect them with the **Bottom Mounting Plate** using the **(M4x6 Philips)** screws provided.
3. Attach the **Rack Ear** to each side of the front of the amplifier assembly using the **(M5x8 Philips)** screws provided.
4. Attach the **Rear Flat Brackets** to each side of the rear of the amplifier assembly with the **(M4x6 Philips)** screws provided.
5. Install the assembly into the cabinet using the rack mount screws through the **Rack Ears**. For details of installation in the chassis of the cabinet, refer to the user guide of your cabinet.
6. Align the **Rear Support Brackets** with the proper holes at the rear of the cabinet and attach using rack mount screws.
7. With the **Rear Support Brackets** to the outside of the **Rear Flat Brackets**, attach them each using the **(10-32, 0.75 Philips)** screw provided, the **Rear Flat Bracket** and the **Rear Support Brackets** as shown in the figure.

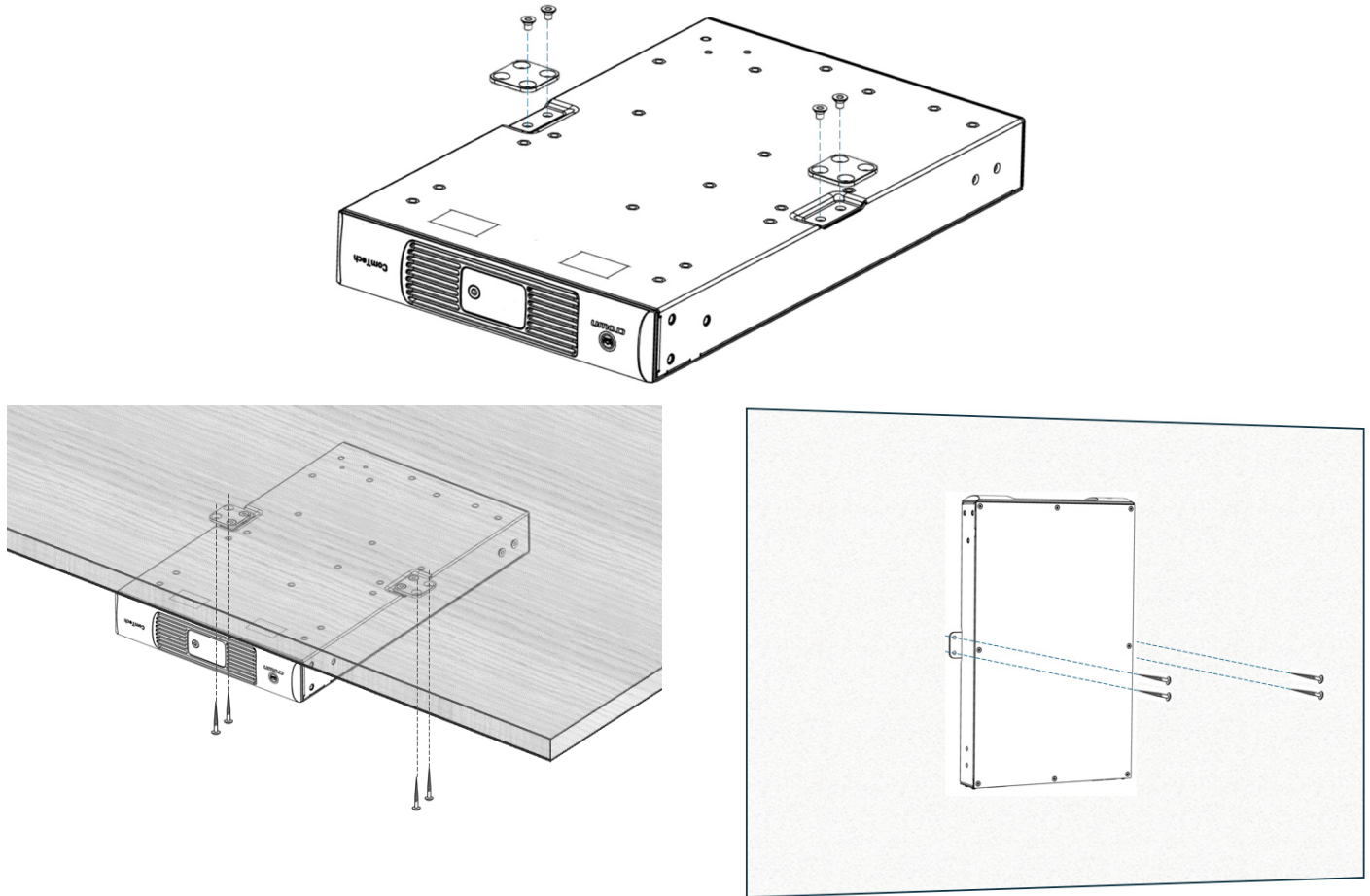
**Wall-Mounting / Under-table Mounting Single Half Rack Unit**

**Figure 4:** *Rack Mounting Two Half Rack Units*

To wall-mounting or under-table mounting, refer to **Figure 4** and follow the steps below:

1. Attach the 2x **Bottom Mounting Plates** on both side of the bottom of amplifier using the **(M4x6 Philips)** screws provided.
2. Install the assembly onto the wall or under the table using the proper screws through the **Bottom Mounting Plates**.
3. Class 8.8, M4 or equivalent US size, self-tap or machinery screw shall be used.
4. All screws must be used at all times.
5. Screw length shall be considered based on wall or table type and thickness.
6. The general condition of the mounting surface shall be considered before installation.

## Installing the Amp

### Additional Materials

For installation, you will need the following (not supplied):

- Input wiring cables
- Output wiring cables
- Flathead screwdriver
- Phillips screwdriver
- Rack for mounting amplifier (or a stable surface for stacking)
- Category 5e or higher cabling



**WARNING:** Before you start to set up your amplifier, read and observe the Important Safety Instructions included in the box. These instructions can also be downloaded from the product page at [www.crownaudio.com](http://www.crownaudio.com).

### Installing the Amplifier



**CAUTION:** Before you begin, make sure your amplifier is disconnected from the power source.

Mount the unit in a standard 19-inch (48.3 cm) equipment rack (EIA RS-310B). You can also place a single amp on a solid, stable surface or stack multiple amps.

**NOTE:** Amplifiers should be supported at both the front and rear of the rack.

See "[Dimension Drawings](#)" for information on amplifier dimensions.

### Proper Cooling

When using an equipment rack, mount units directly on top of each other. Close any open spaces in the rack with blank panels. (Open spaces will reduce cooling efficiency.) DO NOT block front or rear air vents.

The rack should be a minimum of 2 inches (5.1 cm) away from the amplifier, and the back of the rack should be a minimum of 4 inches (10.2 cm) from the amplifier back panel.

Air flow is front to back as illustrated in **Figure 5**.

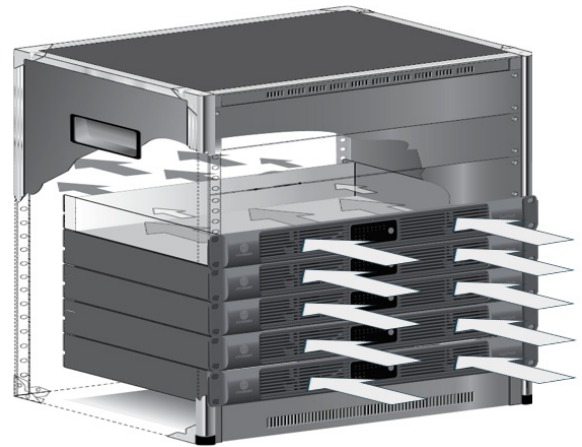

**Figure 5:** Proper rack venting

# Front Panel Overview

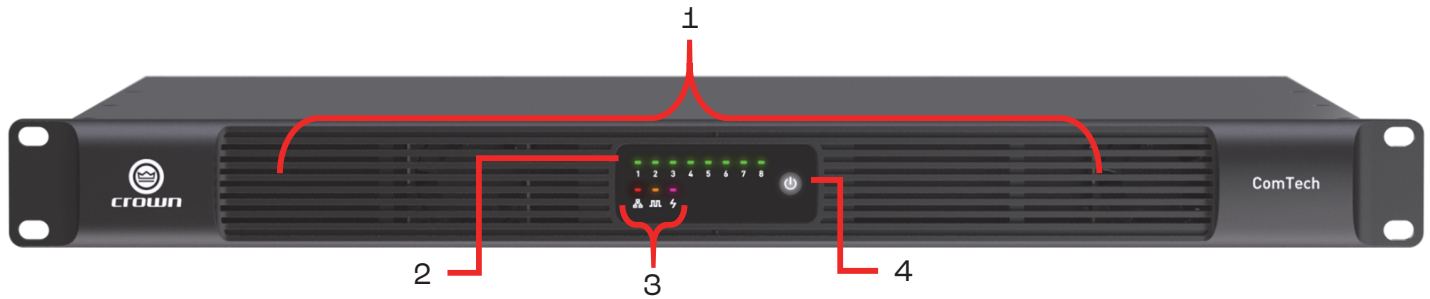

**Figure 6:** CTD-8125 front panel shown

## 1. Cooling Vents

Provides cooling air flow. Do not block or cover these vents.

## 2. Channel LED Indicators

These LEDs indicate channel signal level and health as follows:

●	OFF	Output Signal is not present
●	Solid On	Output Signal is present
●	Solid On	Output Signal is Limiting
●	Solid On	Output Signal is Clipping
★	Flashing	Amplifier Channel is faulty
★	Flashing	[Locate] is Activated

## 3. Status LED Indicators

These LEDs indicate the status of the amplifier as follows:

Data / Network Indicator		
●	OFF	No Network Connection
●	Solid On	Network Connected with no match Software (AVX Suite)
●	Solid On	Network Connected and matched in Software (AVX Suite)
★	Flashing	[Locate] is Activated



### Audio / Dante Indicator

●	Solid On	Booting / Syncing
★	Flashing	Sync Failure
●	Solid On	Sync OK, Boot OK
●	Solid On	Hardware Failure
★	Flashing	Dropped / Corrupt packets
★	Flashing	[Locate] is Activated



### Health Indicator

●	Solid On	Hardware Failure/Fault on Power Supply
★	Flashing	Pilot Tone / Load Monitoring Error
●	Solid On	Thermal Limiting
●	Solid On	Everything OK
★	Flashing	[Locate] is Activated

## 4. Power Button and LED Indicator

Turns the amplifier power on or off. The Power button has an integrated power symbol that illuminate, and it indicate the Power Status as follows:

●	OFF	No Power plugged in
●	Solid On	On and Normal Operation
★	Breathing	Amplifier in ErP Sleep mode
●	Solid On	Power Supply fault
●	Solid On	Power plugged in, Amplifier is Off
★	Flashing	[Locate] is Activated

**NOTE:** The Power Button is disable during GPI Sleep. See "[Configuring the GPI Control Port](#)" for more information

**NOTE:** 8-channel model shown. Indications per channel pair are identical for 4-channel and 2 channel models.

# Rear Panel Overview

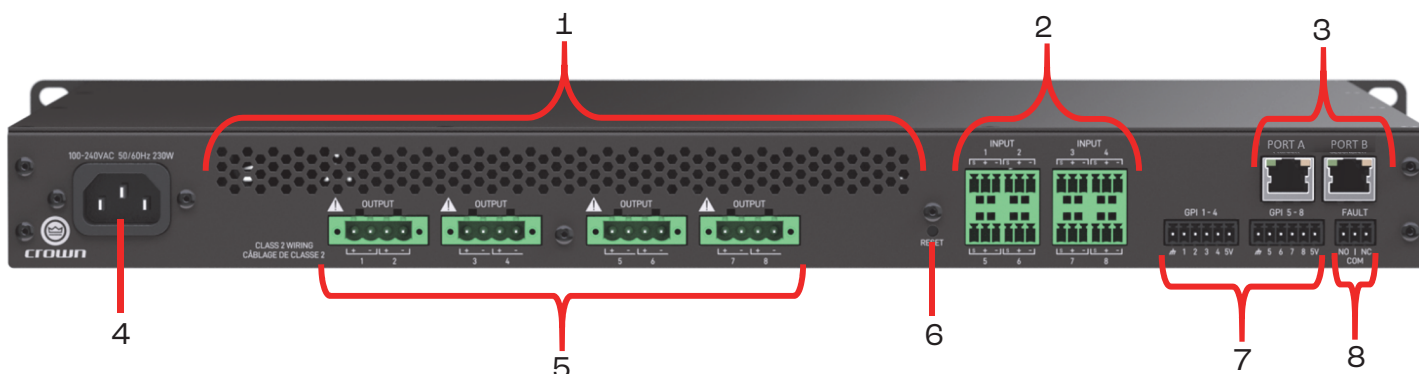

Figure 7: CTD-8125 back panel shown

### 1. Cooling Vents

Provides cooling air flow. Do not block or cover these vents.

### 2. Audio Input (Terminal Block) Connectors

Connect your audio source outputs to these inputs using the provided plug-in connectors. One 6-pin plug-in connector can be used per input pair. These inputs are high impedance, balanced connections. See ["Wiring Input Connectors"](#) for information on wiring these connectors.

### 3. Ethernet (Network Control and Network Audio) Ports

Connect these RJ45 ports to a network for monitoring and controlling the amplifier and send/receive digital audio over Category 5e wiring via the WebUI / Manager Desktop / Dante Controller.

There are 2 RJ45 ports on the ComTech (Port A & Port B), by default these ports is configure as follow:

- Split Mode (Default)
  - Port A = Control Only
  - Port B = Dante Only

For other mode, see ["Configuring the Network"](#).

The integrated LEDs in this Ethernet port will light as follows:

- Yellow LED  
This LED light when a network connection is established with the computer or network and will flash to indicate network activity.
- Green LED  
This LED indicates network speed and will light when connected to a 100Mb network or not light when connected to a 10Mb network.

### 4. AC Power Inlet

Connect the included AC power cord to this standard 13A, IEC type 320 inlet. Supported mains voltage range is 100 – 240V~.

### 5. Output Terminal (Terminal Block) Connectors

One – 4 pins Male Phoenix terminal block with screw lock per channel pair. Accepts up to 12 AWG wire. See ["Wiring Output Connectors"](#) for information on wiring these connectors.

### 6. Reset Button

A momentary push button inside the pin hole.

- Press and hold for 5secs (restore Network setting to Split Mode and DHCP)
- Press and hold for 10sec (perform Factory Reset)
- During the Press and Hold, the front Power LED will flash at slow speed from 0s-5s, then flash at medium speed from 5s-10s, and flash at high speed after 10s.

### 7. General Purpose Input (GPI)

This 6-pin block connector with 4 GPI. See ["Using GPIO Control Port"](#) for further information on configuring and using these ports.

### 8. Fault Output

This 3-pin block connector with 1 GPO. See ["Using GPIO Control Port"](#) for further information on configuring and using these ports.

**NOTE:** Fault Output will report fault when the amplifier is in SLEEP MODE.

## Hardware Setup

### Connecting the Network Cable

By default, the Port A is assigned to HControl, and Port B is assigned to Dante/AES67 digital network audio only, as shown on **Figure 8**. See "[Configuring the Network](#)" for more information.

**WARNING:** Only connect to networks that remain inside the building.



**Figure 8:** Network Ports

### Connecting the AC Power Cord

**IMPORTANT:** The amplifier output mode must be properly configured for the application before connecting the speakers and powering on the amplifier. By default, all outputs are configured for Low Z operation. See "[Configuring Output Mode](#)" for more information.

Connect your amplifier to the AC mains power outlet using the supplied AC power cord. First, connect the IEC end of the cord to the IEC connector on the amplifier. Then plug the other end of the cord to the AC mains.



**WARNING:** The third prong of the power connector (ground) is an important safety feature. Do not attempt to disable this ground connection by using an adapter or other methods.

Make certain the AC mains voltage and current ratings are sufficient to deliver full power to all amplifiers. ComTech D Series amplifiers use a universal power supply. The AC voltage requirements are 100V-240V~, 50/60Hz ±10%. If the AC line voltage varies outside of this acceptable range, the amplifier's power supply will turn off and the blue Power LED will flash. The amplifier will turn back on when the AC line voltage returns to safe operating levels.

### Power Up Procedure

When turning on the amplifier for the first time:

1. Ensure all connections are disconnected with the exception of the power cord and network.
2. Press the amplifier's **POWER** button. The Power indicator will light up Green once the amplifier boot up is completed.
3. Once boot up is complete, configure the amplifier as described in "[WebUI – Configuring the Inputs and Outputs](#)".  
**NOTE:** The amplifier output mode must be properly configured for the application before connecting the speakers and powering on the amplifier. By default, all outputs are configured for Low Z operation.
4. Once the amplifier has been properly configured for the application, turn off the power – by pressing and holding the Power button for 2 seconds – then disconnect the power cord.
5. Turn down the level of your audio source.
6. Make all connections as described in "[Wiring Input Connectors](#)" and "[Wiring Output Connectors](#)".
7. Once all connections have been made, reconnect the power cord and turn on the amplifier power.
8. Turn your audio source up to an optimum level. Refer to all device meters and ensure that at no point in the signal chain is the signal being clipped in any way. If any of the amplifier's Channel indicators' light Amber, reduce the source level until the Channel LEDs no longer light up Amber.
9. Adjust the amplifier output level until the desired loudness or power level is achieved, while making sure the amplifier's Channel LEDs do not light up Amber.

**IMPORTANT:** Always turn off the amplifier – by pressing and holding the Power button for 2 seconds – and disconnect the power cord before making any wiring or installation changes.

**IMPORTANT:** When powering a fully configured PA system, always turn the amplifiers on last and off first.

For help with determining your system's optimum gain structure (signal levels) please refer to the Crown Amplifier Application Guide, available online at [www.crownaudio.com](http://www.crownaudio.com).

### Precautions

Your amplifier is protected from internal and external faults, but you should still take the following precautions for optimum performance and safety:

1. Configure the amplifier for proper operation, including input and output wiring hookup. Improper wiring can result in serious operating difficulties.  
For information on wiring and configuration, please consult "[Wiring Input Connectors](#)" and "[Wiring Output Connectors](#)".  
For advanced setup techniques, consult Crown's Amplifier Application Guide available online at [www.crownaudio.com](http://www.crownaudio.com).
2. Use care when making connections, selecting signal sources, and controlling the output level. The load you save may be your own!
3. Do not short the ground lead of an output cable to the input signal ground. This may form a ground loop and cause oscillations.
4.  **Never connect the output to a power supply, battery, or power main. Electrical shock may result.**
5. Tampering with the circuitry or making unauthorized circuit changes may be hazardous and invalidate all agency listings.
6. Do not operate the amplifier with the Channel LEDs constantly flashing Amber (Clipping).
7. Do not overdrive the mixer, which will cause clipped signal to be sent to the amplifier. Such signals will be reproduced with extreme accuracy, and loudspeaker damage may result.
8. Do not operate the amplifier with less than the rated load impedance. Due to the amplifier's output protection, such a configuration may result in premature clipping and speaker damage.

**REMEMBER:** Crown is not liable for damage that results from overdriving other system components.

## Wiring Input Connectors

Crown recommends using pre-built or professionally wired balanced cables (two-conductor plus shield). Balanced wiring provides better rejection of unwanted noise and hum, however, unbalanced line may also be used.

Use 3-pin plug-in cable ends at the amp input connectors. A male connector is supplied for each input of your model of amplifier.

**Figure 9** shows connector pin assignments for balanced wiring and **Figure 10** shows connector pin assignments for unbalanced wiring.



**Figure 9:** *Balanced wiring*

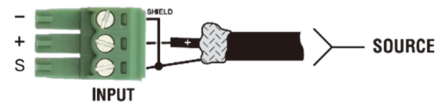

**Figure 10:** *Unbalanced wiring*

## Wiring Output Connectors

**IMPORTANT:** The amplifier output mode (Low Z, 70V, 100V) must be properly configured for the application before connecting the speakers. By default, all outputs are configured for Low Z operation. See "[Configuring Output Mode](#)" for more information.

Before making any output connections, ensure the power cord is disconnected from the amplifier and carefully review the total impedance for loudspeakers connected to each amplifier output. If multiple loudspeakers are connected to an output in Low Z mode (i.e., in series, parallel, or series-parallel), be certain the total system impedance is within allowed specification for the output. When multiple loudspeakers are connected to one output in High Z mode, be certain total tapped power is below the rated power output for the channel. See "[Specification](#)" for supported load specifications.

Crown recommends using professionally constructed, high quality, two-conductor, heavy gauge speaker wire and connectors. Use 4-pin Phoenix-type connectors (Included with the amp). (see **Figure 11**).

Suggested below are guidelines to select the appropriate size of wire based on the distance from amplifier to speaker for low-impedance loads. Check with local code as this may vary.

Distance	Wire Size
Up to 25ft. (7.6m)	16 AWG
26-40ft. (7.9-12.2m)	14 AWG
>41ft (18.3m)	12 AWG

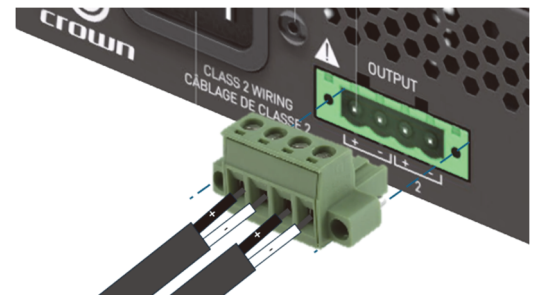

**Figure 11:** *Wiring output connectors*



**CAUTION:** Never use shielded cable for output wiring.



**CAUTION:** Never connect the speaker return to the chassis of the amplifier, or damage to the amplifier may result.



**NOTE:** Custom wiring should only be performed by qualified personnel. Class 2 output wiring is required.

## Installing the Software and Configuring the Network

### Installing Manager Desktop

The Discovery, Device setting, Network setting and Firmware Update for ComTech D Series amplifiers can be configured using Manager Desktop. The latest version of Manager Desktop can be downloaded from <https://www.amx.com/en/software/manager-desktop-v1-03-0-205>. To install Manager Desktop, launch the software installer and follow the on-screen installation instructions.

### Launching Manager Desktop

To communicate with Manager Desktop, the amplifier must be connected to a TCP/IP network via the rear panel Ethernet port (Port A). When Manager Desktop launches, it will automatically discover any compatible Harman devices on your network. The device grid will be populated with all discovered devices. See **Figure 12**.

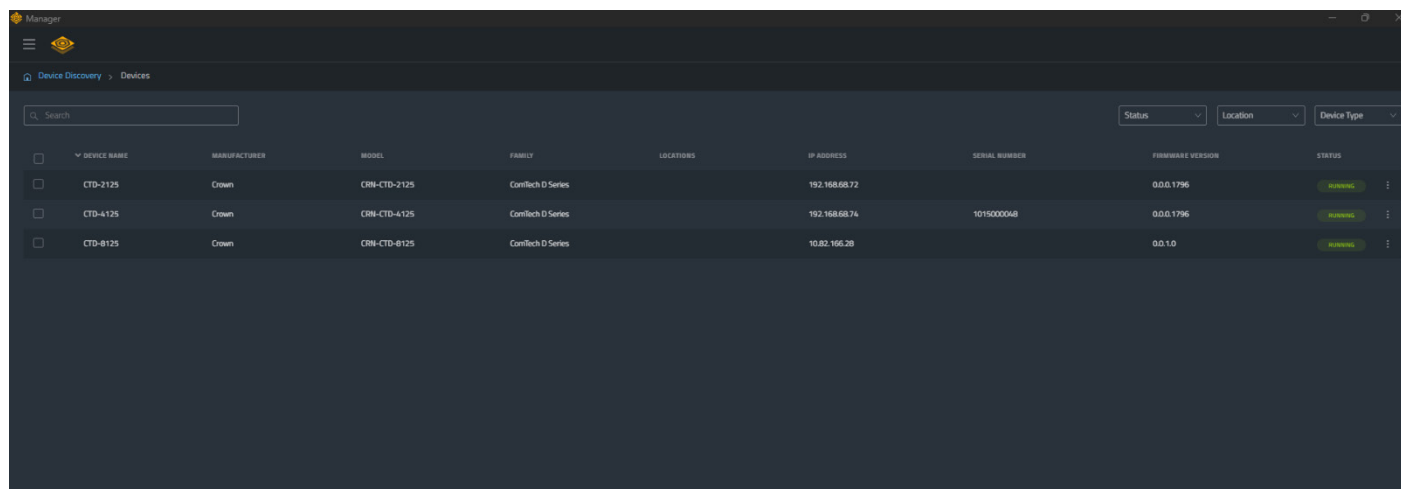

**Figure 12:** Device discovery grid

**NOTE:** PORT B cannot be used for control and monitoring of the amplifier.

## Device Configuration

From the device discovery grid, check the box of one or more devices to select the device. This will display the actions bar at the bottom of the application window. Select "Configure..." to configure the selected devices. The configuration screen is data driven and dependent on the parameters provided by the device. See **Figure 13**.

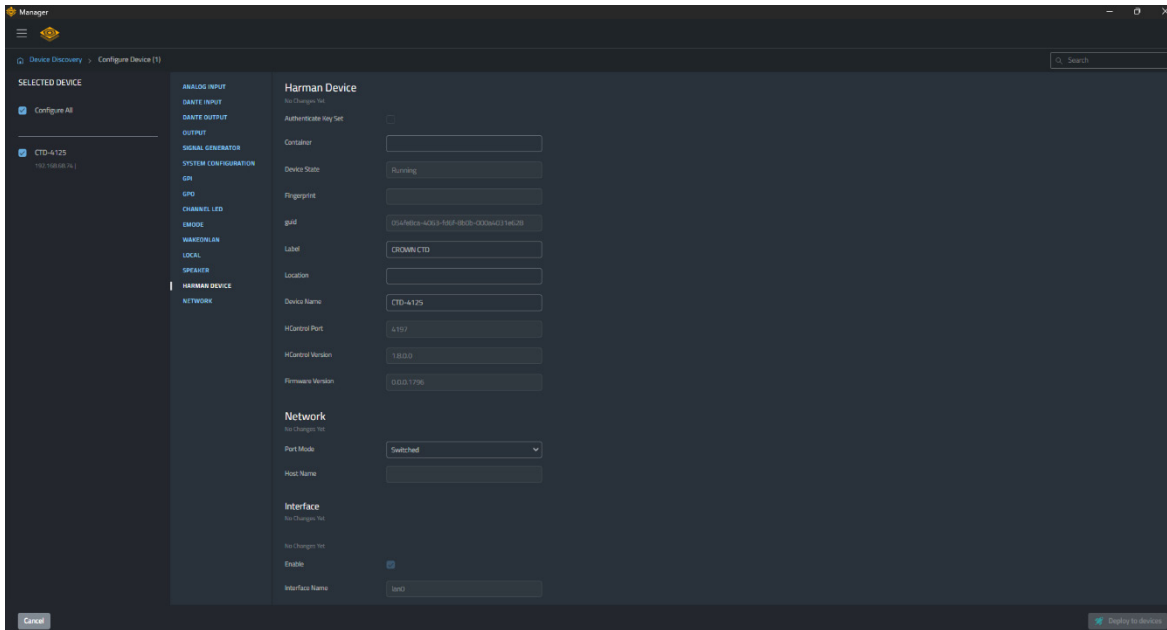

Figure 13: Device configuration screen

## Network setting

The Network setting can be configured under Network. See **Figure 14**.

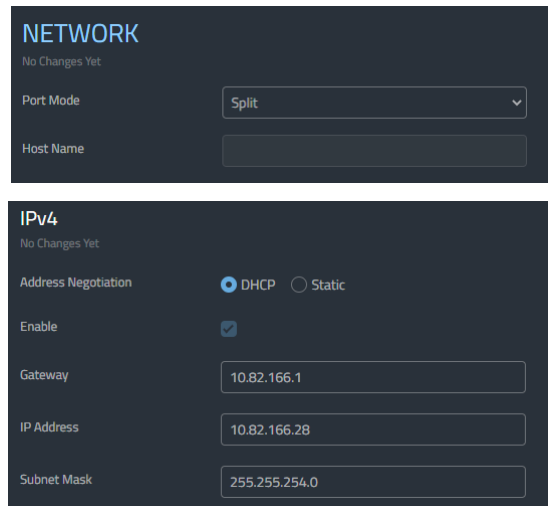

Figure 14: Device configuration screen

## Installing the Software and Configuring the Network

### Network Port Mode

There are three modes for the Network Ports "Redundant", "Split" (by default), and "Switched"

- Redundant Mode
  - Port A – Dante/AES67 Primary Signal + HControl
  - Port B – Dante/AES67 Secondary Signal
- Split Mode (By Default)
  - Port A – HControl
  - Port B – Dante/AES67 Primary Signal
- Switched Mode
  - Port A – Dante/AES67 Primary Signal + HControl
  - Port B – Dante/AES67 Primary Signal + HControl (loop out)

### Network DHCP/Static IP

Click on either DHCP / Static IP allow you to change a device to DHCP / Static IP. The device will attempt to have its IP settings configured by DHCP on applying the edits; if no DHCP server is present, the device will attempt to have IP settings configured by Auto-IP.

### IP Address

Displays the IP address of the discovered device. A valid IP address may be edited inline.

### Network Mask

Displays the Subnet Mask of the discovered device. The Subnet Mask may be edited inline.

### Gateway

Displays the Default Gateway of the discovered device. The Default Gateway may be edited inline.

### DNS1

Displays the Domain Name System 1 of the discovered device. The Domain Name System 1 may be edited inline.

### DNS2

Displays the Domain Name System 2 of the discovered device. The Domain Name System 2 may be edited inline.

## Firmware Update

When a firmware update becomes available on our remote repository. An update firmware icon will appear in the Firmware Version column. Click this icon to update to the latest firmware. See **Figure 15**.

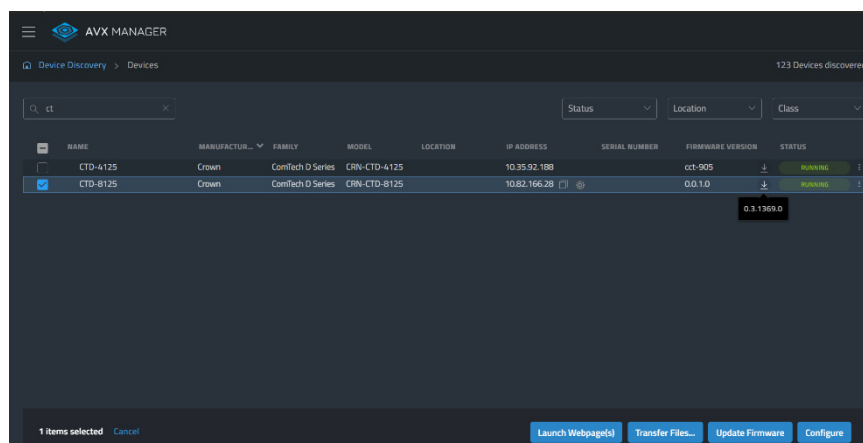
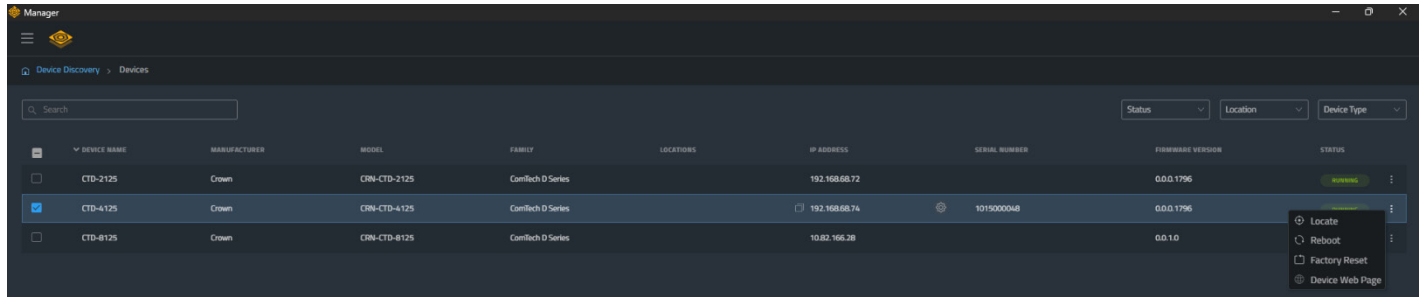

Figure 15: Firmware Update

## Reboot, Locate, Factory Reset & Launching WebUI (Web User Interface)

To reboot, locate, factory reset a device or launching the WebUI, click the 3-dot menu of a device row to open its context menu. Select the desired action. See **Figure 16**.



**Figure 16:** Device context menu for locate, reboot, factory reset and launching WebUI

## WebUI – Overview Page

The ComTech D Series amplifiers are configured, controlled, and monitored using WebUI.

Once you enter the WebUI, it will land on the OVERVIEW Page as shown in **Figure 17**. This page provides a quick overview of all the Analogue Inputs, Dante Inputs, Dante Outputs, Amplifier Outputs, Incoming Pilot Tone, and Load Monitoring, etc...

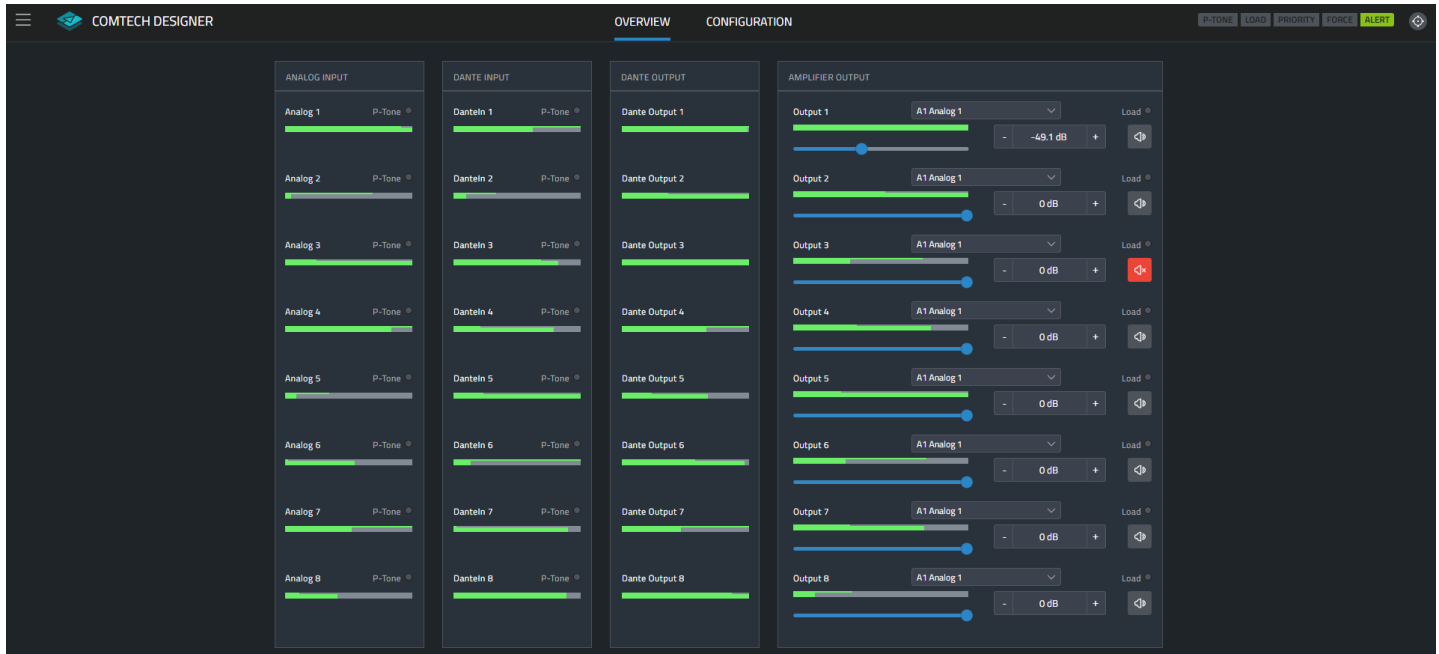

Figure 17: Overview Page

### Analog Input & Dante Input (READ ONLY)



- Input Signal Name; See ["WebUI – Configuring the Inputs and Outputs"](#)
- Input Level Meter
  - The meter displays both PEAK and RMS level, and at clipping level the color of the meter will turn RED.
- Incoming Pilot Tone Monitoring; See ["Configuring Incoming Pilot Tone Monitoring"](#)
  - Green – Signal level / frequency is within the range
  - RED – Signal level / frequency is outside the range
  - Grey – Incoming pilot tone monitoring for this channel is turn OFF

### Dante Output (READ ONLY)

- Output Signal Name
  - It will display the name of the channel that patched to the Dante Output; See ["WebUI – Dante Output Patching"](#)
- Output Level Meter (READ ONLY)
  - The meter displays both PEAK and RMS level, and at clipping level the color of the meter will turn RED.

## Amplifier Output (EDITABLE)

This section provided users with quick access to change some of the parameters for each output channel.

- Output Signal Name (READ ONLY); See ["WebUI – Configuring the Inputs and Outputs"](#)
  - Source for the Output channel
    - A drop-down menu allow users to change the 1<sup>st</sup> Source for each Output channel.
- A1 Channel 1
- Output Level Meter (READ ONLY)
    - The meter displays both PEAK and RMS level, and at clipping level the color of the meter will turn RED.
  - Channel Output Level Adjustment
    - Sliding fader
- 
- Up / Down toggle switch
- 0.00 dB
+
- Mute Control 
  - Output Load Monitoring (READ ONLY); See ["Configuring Output Load Monitoring"](#)
    - Green – Load is within the range
    - RED – Load is outside the range
    - GREY – Load Monitoring for this channel is turn OFF

## Pilot Tone, Load, Priority, Force and Alert Monitoring

There are indicators and buttons on the top right corner of the WebUI which provide a quick overview of the status of the amplifier including Incoming Pilot Tone, Output Load, Source Priority, Force 2<sup>nd</sup> Source and Temperature. See **Figure 18**.

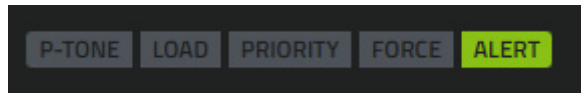

**Figure 18: Monitoring Quick Overview**

- P-TONE refers to Incoming Pilot Tone
  - When all Pilot Tone Detectors are turned OFF, the indicator will be in GREY
  - When one or more Pilot Tone Detector is turned ON, and all detected Pilot Tone are within range, the indicator will be in GREEN
  - When one or more Pilot Tone Detector is turned ON, and any one of the Pilot Tone are detected out of range, the indicator will be in RED
- LOAD refers to Output Load Monitoring
  - When all Output Load Monitoring are turned OFF, the indicator will be in GREY
  - When one or more Output Load Monitoring is turned ON, and all detected Load are within range, the indicator will be in GREEN
  - When one or more Output Load Monitoring is turned ON, and any one of the Load are detected out of range, the indicator will be in RED
- PRIORITY refers to Source Priority
  - When all Source Priority Mode are not in Backup Mode, the indicator will be in GREY
  - When one or more Source Priority is in Backup Mode, and all Outputs remain on 1<sup>st</sup> Source, the indicator will be in GREEN
  - When one or more Source Priority is in Backup Mode, and any one of the Output is switched to 2<sup>nd</sup> Source (due to Pilot Tone / Signal Sensing), the indicator will be in RED

## WebUI – Overview Page

---

- FORCE refers to Force 2<sup>nd</sup> Source
  - When all Source Priority are not in Backup Mode, the indicator will be in GREY
  - When one or more Source Priority is in Backup Mode, and all Force 2<sup>nd</sup> Source is OFF, the indicator will be in GREEN
  - When one or more Source Priority is in Backup Mode, and any one of the Force 2<sup>nd</sup> Source is ON, the indicator will be in RED
- ALERT refers to warning message for Line Integrity, Clipping and Limiting, and Hardware Temperature
  - When there is no warning on the amplifier, the indicator will be in GREEN
  - When there is any warning on the amplifier, the indicator will be in RED

P-TONE / LOAD / ALERT indicators are also buttons, clicking them will bring user to the Pilot Tone and Load Monitoring or ALERT Page.



### Locate

The "Locate" button is at the top right corner of the WebUI. The Locate feature allows a device to be easily identified within a network full of H-Control devices. Clicking in the Locate button for a device will put the corresponding networked device into a Locate state — the Locate icon will be displayed on-screen and something will happen on the device to indicate the Locate state is active (e.g., an LCD or LED will flash, etc.). Clicking an active Locate icon will disable the Locate state for the device. Disabling the Locate state from the device will clear the icon. Devices may be put into a Locate state independently from selection so that more than one device can be located at any one time.

## WebUI – Configuring the Inputs and Outputs

### Configuration Page

Clicking on the CONFIGURATION on the top center of the WebUI will bring you to the configuration page. See **Figure 19**.

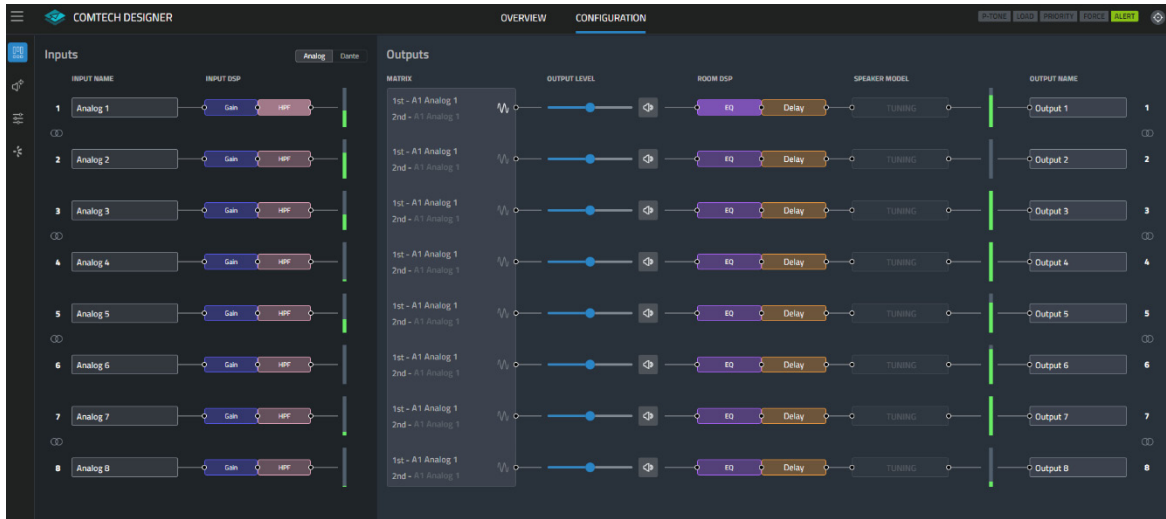

**Figure 19: Configuration Page**

The left section on this Page shows all your input channels, and the Right section on this page model shows all your output channels. Users can edit the channel name, stereo link two channels, and adjust the output volume & mute in this page.

### Channel Naming

Click on the name of the channel (applies to both Input and Output), allow you to edit the default name to user-defined names, which can be used for reference.

### Switch between Analog Input and Dante Input

To switch view and edit the Dante Input Channel, click on the Dante to change the Inputs page from Analog to Dante and vice versa. See **Figure 20**.



**Figure 20: Analog/Dante Input**

### Stereo Linking

To Stereo linking two channels (applies to both input and output), click on the pairing icon between the channel above / below the channel number, a confirmation window will pop up to ask for confirmation. See **Figure 21**.

**NOTE:** All changes to the parameters on the second channel will be replaced by the first channel once the 2 channels are Stereo Linked.

Stereo Linking can only be done on 1&2, 3&4, 5&6 and 7&8. Once the channels are linked, the parameters will be linked together. Any editing on the parameters will apply to both channels.

To unlink the channels, click the Stereo Link icon again and the link between the parameters will break, and the name of the channel will return to its default name.

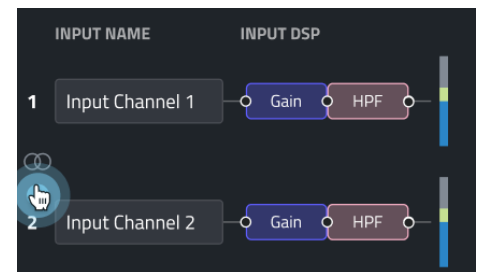
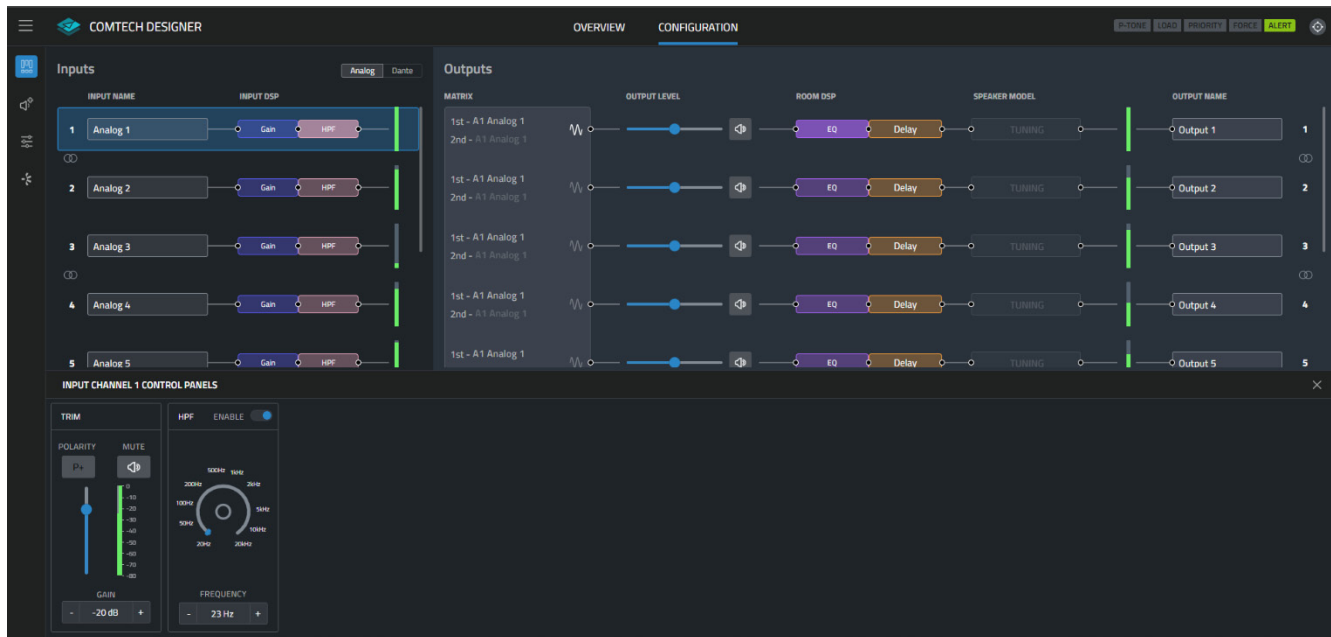

**Figure 21: Stereo Linking**

# WebUI – Configuring the Inputs and Outputs

## Configure the Inputs

To configure the Input DSP, click on any input channel and the Control Panel for that channel will pop-up at the bottom of the WebUI. See **Figure 22**.



**Figure 22: Input Control Panel**

While the Control Panel is open, the top section Inputs/Outputs become scrollable allow user to navigate to other input/output that are visually blocked by the Control Panel. To close the Control Panel, there is a "X" icon on the top right side of the Control Panel.

### Trim and Mute Control

The level faders, "+/-" toggle switch, number input are used to adjust signal levels entering the DSP chains from the various input sources. The meters in this panel display the RMS levels. When the signal is clipping, the meters will turn from green to amber. There are also Polarity Control and Mute Control per input. See **Figure 23**.

### HPF (High Pass Filter) Control

The Rotary, "+/-" bump switch, number input are used to set the frequency of the high-pass filter of the signal entering the DSP chains from various input sources. The HPF is fixed filter Linkwitz-Riley 48. There is also an ENABLE ON/OFF control to "enable" or "disable" this HPF. See **Figure 23**.



**Figure 23: Input Trim and HPF Control Pane**

## Configure the Outputs

To configure the Output DSP, click on any output channel and the Control Panel for that channel will pop-up at the bottom of the WebUI. See **Figure 24**.

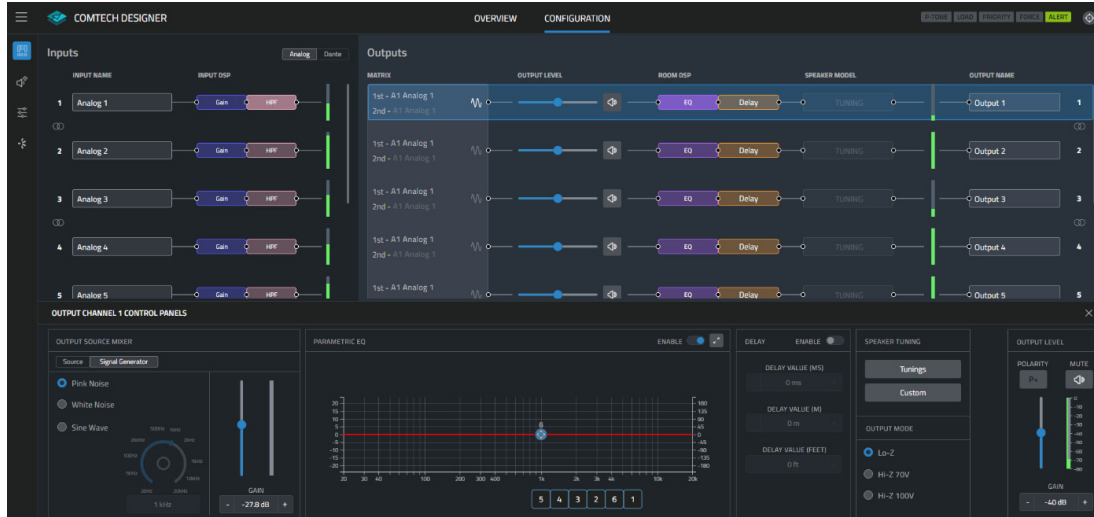

**Figure 24: Output Control Panel**

While the Control Panel is open, the top section Inputs/Outputs become scrollable allow user to navigate to other input/output that are visually blocked by the Control Panel. The Control Panel at the bottom is also Swipearable for more control options (if the WebUI is zoomed in) which include Source Mixer, Parametric EQ, Delay, Speaker Tuning, etc... To close the Control Panel, there is a "X" icon on the top right side of the Control Panel.

## Using Output Source Mixer Panel

Each Output Channel will have a 1<sup>st</sup> Source, 2<sup>nd</sup> Source and Signal Generator routed to it. See **Figure 25, 26**.

### 1<sup>st</sup> Source

- The drop-down menu allows users to select the main source for the Output Channel
- The bump control allows users to fine tune the level of the playback source without affecting other Output Channels using the same source.

### Mode (OFF / MIX / BACKUP)

- OFF: The Output Channel will solely playback 1<sup>st</sup> Source, and 2<sup>nd</sup> Source will be disabled
- MIX: The Output Channel will playback the mix of 1<sup>st</sup> Source and 2<sup>nd</sup> Source.
- BACKUP: The Output Channel will playback 1<sup>st</sup> Source and use 2<sup>nd</sup> Source as a Backup Source.
  - When Pilot Tone Detector on the 1<sup>st</sup> Source is ON, the trigger to switch to 2<sup>nd</sup> Source will be based on the absence of the pilot tone on the 1<sup>st</sup> Source.
  - When Pilot Tone Detector on the 1<sup>st</sup> Source is OFF, the trigger to switch to 2<sup>nd</sup> Source will be based on the absence of the input signal on the 1<sup>st</sup> Source.

### 2<sup>nd</sup> Source

- The drop-down menu allows users to select the backup source for the Output Channel.
- The bump control allows users to fine tune the level of the playback source or adjust the level between 1<sup>st</sup> Source and 2<sup>nd</sup> Source without affecting other Output Channels using the same source.
- Click the Force button under 2<sup>nd</sup> Source is only available with Mode is set to BACKUP, and enable it will force the output to playback from the 2<sup>nd</sup> Source.

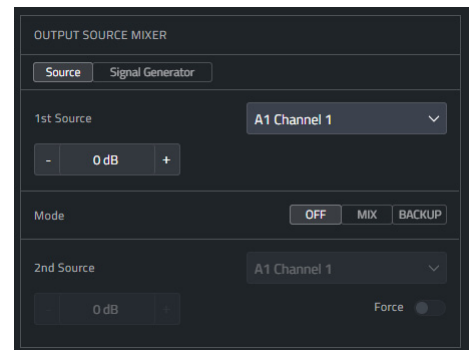

**Figure 25: Output Source Mixer**

## WebUI – Configuring the Inputs and Outputs

### Signal Generator

The signal generator can be used to tune or troubleshoot loudspeakers connected to the amplifier. The Signal Generator panel can be accessed by clicking the **Signal Generator** button next to the Source in the Output Source Mixer, see **Figure 26**. Once Signal Generator button is selected, the Signal Generator will get mixed and output to the channel. The icon  on the Configuration Page on that Output Channel will light up to remind users that the Signal Generator is currently active and mixed to the Output.

#### Available Options / Parameters

- Type (Pink, White, Sine)
  - Selects the type of signal to be generated from the global Signal Generator.
- Amplitude Fader (-60dBFS to 0dBFS)
  - The level of the global signal generator remains 0dBFS, this only adjusts the individual signal feeds to the output channel.
- Frequency (20Hz – 20kHz)
  - Selects the sine tone frequency when the "Sine Wave" type has been selected

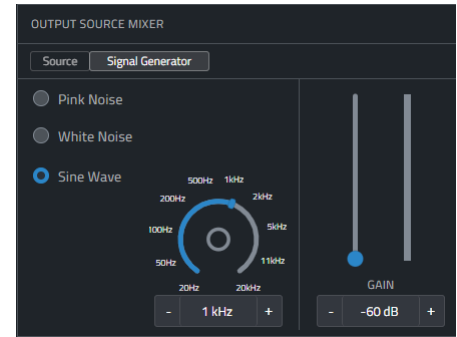

**Figure 26: Signal Generator Panel**

### Parametric EQ Panel

Parameter EQ can be adjusted by expanding the Parametric EQ Screen by clicking the expand icon see **Figure 27, 28**. This PEQ is used for room tuning.

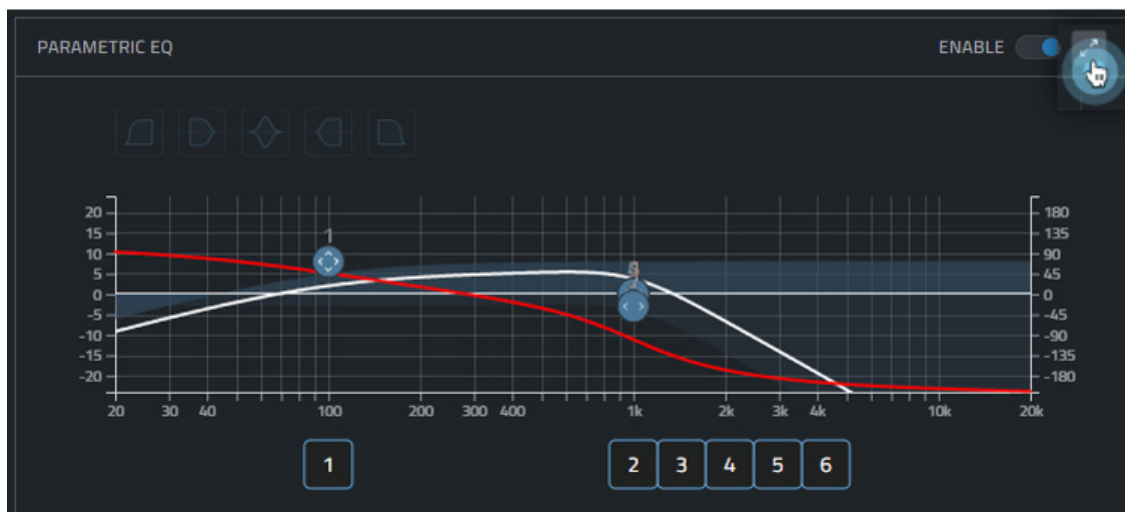

**Figure 27: Parametric EQ**



**Figure 28:** Parametric EQ expanded Control

There are 9 types of filters can be added up to 6 bands, it can be a combination of:

- Bell filter
- Variable Low shelf filter
- Variable High shelf filter
- Low pass filter (1<sup>st</sup> Order)
- High pass filter (1<sup>st</sup> Order)
- Low pass filter (2<sup>nd</sup> Order)
- High pass filter (2<sup>nd</sup> Order)
- All pass filter (1<sup>st</sup> Order)
- All pass filter (2<sup>nd</sup> Order)

Users can control the following parameters through the control on both the bottom and from the EQ graph.

- Band # (1-6)
- ENABLE (On/Off)
- Frequency (20Hz – 20kHz, increment of 1Hz)
- Gain (-24dB – 24dB, increment of 0.1)
- Q (0.1 – 32, increment of 0.05)
- Slope (3,6,9,12,18,24 dB/Oct)

## WebUI – Configuring the Inputs and Outputs

### Adjusting Room Delay

The room delay provides up to 100msec (with increment of 0.1ms) of delay time and can be used for delaying the system to the stage backline, delay fills, or another application which require time alignment.

Delay can be adjusted from the Delay Panel on the right next to the Parametric EQ Panel, see **Figure 29**.

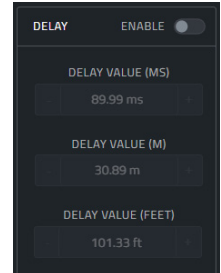
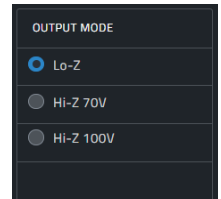

**Figure 29:** Delay Panel

### Configuring Output Mode

Each output can be independently configured for Low Z or High Z (70V/100V) operation. See **Figure 30**.

The Output Mode Panel is located on the right next to the Delay Panel.



**Figure 30:** Output Mode

### Speaker Tuning Panel

#### Speaker Tuning

Speaker tunings apply DSP settings specific to a particular speaker, making it easy to optimize a speaker's performance.

JBL Speaker Tuning Library for ComTech D-series are available to download via the WebUI, the procedure of download is shown in Device Setting. Once the latest Speaker Tuning is downloaded, click "Tunings" in the Speaker Tuning Panel shown in **Figure 31**, a Speaker Tuning selector will pop up see **Figure 32**. The Speaker Tuning Selection method will be sorted by Brand / Series / Model / Usage / Channel Band Selection / Option, once the correct speaker model is selected, click Apply to load the Speaker Tuning.

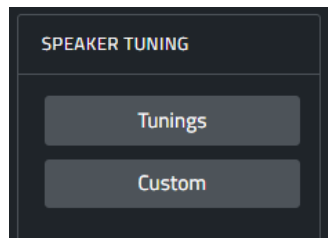

**Figure 31:** Speaker Tuning Panel

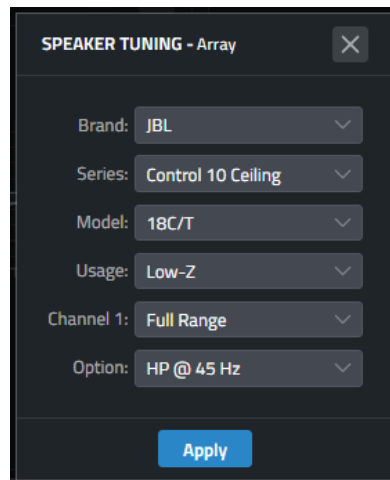

**Figure 32:** Speaker Selection

**NOTE:** After applying the speaker tuning, please ensure the Output Mode (Lo-Z, Hi-Z 70V, Hi-Z 100V) is matched with the speaker connected, selected an Hi-Z speaker tuning will not change the Output Mode.

**NOTE:** If the output channel is Stereo, please load the JBL Speaker Tuning or adjust the Custom Speaker Tuning after Stereo Link is Enable.

### Custom Speaker Tuning

Custom Tuning allows users to create their own DSP setting for speakers that are not included in the JBL Speaker Tuning Library.

Clicking "Custom" in the Speaker Tuning Panel shown in **Figure 31**, a Custom Tuning Window will pop up see **Figure 33**. user can also manually enter the Crossover, PEQ, Delay, LevelMax™ Limiter value for other speakers.

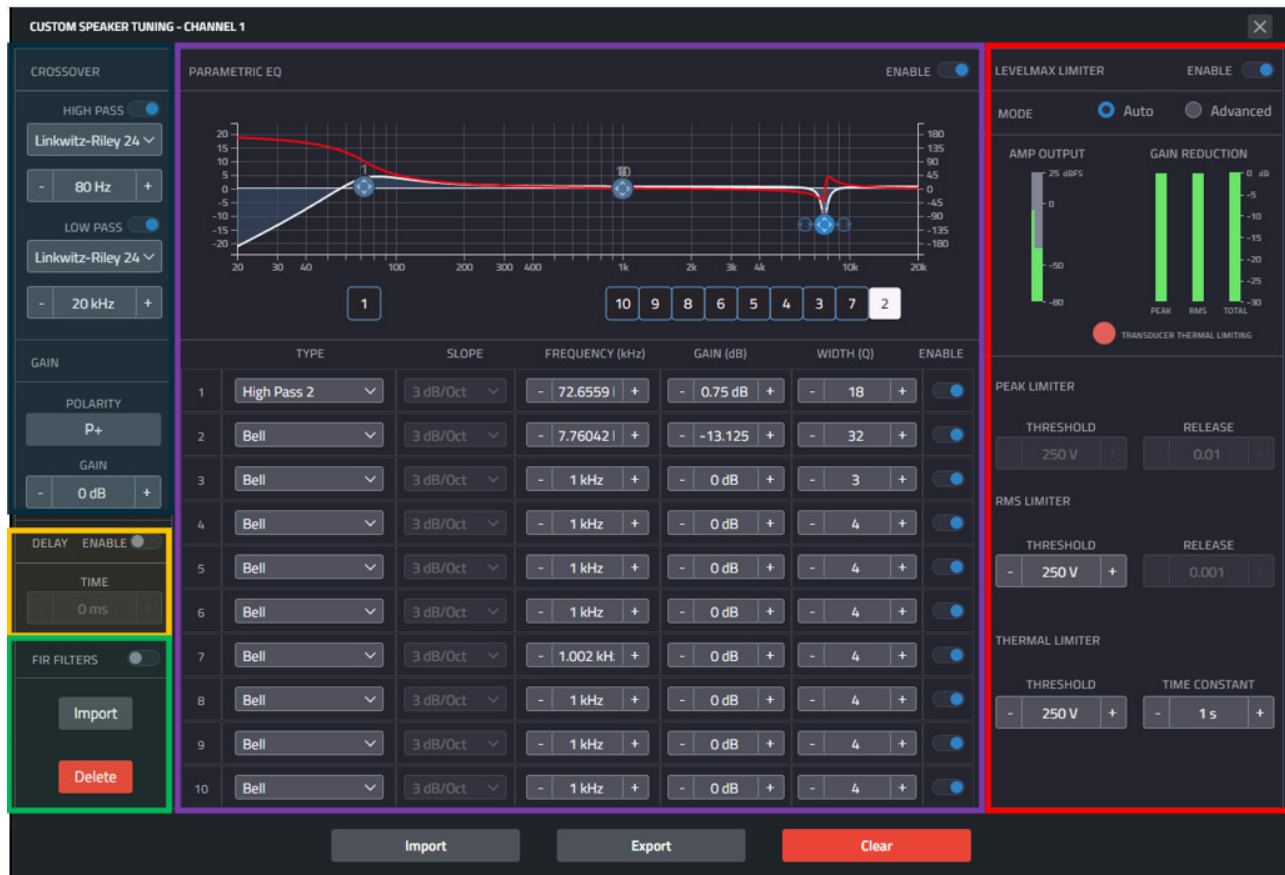

**Figure 33: Custom Tuning**

User can Import, Export or Clear the Custom Speaker Tuning from the bottom of the Custom Tuning Panel.

- **Import** – importing from a previously export (\*.CTD Series.CustomSPK) Custom Tuning file from the PC.
- **Export** – exporting the current Custom Tuning file (\*.CTD Series.CustomSPK) to the PC
- **Clear** – clear all the parameter and set it back to default value in this Custom Tuning

## WebUI – Configuring the Inputs and Outputs

### Adjusting Crossover and Gain (BLUE on Upper Left on Figure 33)

The Crossover provides infinite impulse response (IIR) filters. Each filter can be Enabled or Disabled.

Available low-pass / high-pass filter types:

- Bessel: 6dB/oct, 12dB/oct, 18dB/oct, 24dB/oct, 30dB/oct, 36dB/oct, 42dB/oct, 48dB/oct.
- Butterworth: 6dB/oct, 12dB/oct, 18dB/oct, 24dB/oct, 30dB/oct, 36dB/oct, 42dB/oct, 48dB/oct.
- Linkwitz-Riley: 12dB/oct, 24dB/oct, 36dB/oct, 48dB/oct.

Processing output Gain with -100dB to +20dB and Priority can also be adjusted.

### Delay (YELLOW on Left on Figure 33)

The Speaker Tuning delay provides up to 10msec (with increment of 0.1ms) of delay time and can be used for delaying the drivers within a 2-ways loudspeaker.

### FIR Filter (GREEN on Bottom Left on Figure 33)

The FIR Filter can import mathematically created FIR filter coefficients exported from other applications. The maximum number of Coefficients that ComTech D Series will accept is 512.

- Import: file format (.csv files | .txt files | .json files)
- Delete: This will remove the FIR Coefficients from the speaker tuning

### Parametric EQ (MAGENTA on Middle Top on Figure 33)

Parameter EQ can be adjusted by entering the parameter directly or by expanding the Parametric EQ Screen by clicking the expand icon. This PEQs used for speaker tuning.

There are 9 types of filters can be added up to 10 bands, it can be a combination of:

- Bell filter
- Variable Low shelf filter
- Variable High shelf filter
- Low pass filter (1<sup>st</sup> Order)
- High pass filter (1<sup>st</sup> Order)
- Low pass filter (2<sup>nd</sup> Order)
- High pass filter (2<sup>nd</sup> Order)
- All pass filter (1<sup>st</sup> Order)
- All pass filter (2<sup>nd</sup> Order)

Users can control the following parameters through the control on both the bottom and from the EQ graph.

- Band # (1-10)
- ENABLE (On/Off)
- Frequency (20Hz – 20kHz, increment of 1Hz)
- Gain (-24dB – 24dB, increment of 0.1)
- Q (0.1 – 32, increment of 0.05)
- Slope (3,6,9,12,18,24 dB/Oct)

**LevelMAX™ Limiter Suite (RED on Right on Figure 33)**

The LevelMAX™ has been designed to limit accurately to the specified voltage thresholds. The addition of a thermal limiter allows thresholds for faster-acting RMS and peak limiter to be set higher, providing more output and maintaining dynamic range before the onset of limiting, while protecting the long-term integrity of the transducers.

There are 2 modes of operation (Auto, Advanced). In both Auto and Advanced modes, turning on the LevelMAX Limiter Suite will enable all three limiters: Peak, RMS and Thermal. We'll expand on LevelMAX's limiter types and operating modes below.

**NOTE:** Operating in Manual mode are only recommended under Crown's Application Team's supervision.

**1.0 LevelMAX Peak Limiter**

LevelMAX Peak limiting instantaneously limits the output voltage so it will not exceed the defined peak threshold voltage.

**1.1 Peak Limiter Threshold****User-Defined Setting**

In Auto mode, the peak limiter threshold value is automatically determined from the defined RMS threshold and the lowpass frequency. These values are set in the CROSSOVER located on the left. When a lowpass frequency is below 100 Hz, the RMS-to-peak threshold ratio is 6 dB. When the lowpass frequency is between 100 Hz to 400 Hz, the RMS-to-peak ratio increases from 6 dB to 9 dB. Above 400 Hz, the ratio remains at 9 dB.

**1.2 Peak Limiter Release****User-Defined Setting**

In Auto mode, peak limiter release time is determined by the HIGH PASS frequency defined in the CROSSOVER. In Advanced mode, peak limiter release time can be set by the user.

**2.0 LevelMAX RMS Limiter**

LevelMAX RMS limiting accurately limits the output signal to the specified RMS threshold voltage.

**2.1 RMS Threshold****User-Defined Setting**

The RMS Threshold should be set by the user to correspond to the transducer or system's short-term (2-hour) power-handling rating. Refer to the appropriate JBL specification sheet, technical manual or product manual for 2-hour power ratings. To calculate the RMS threshold in VRMS, use the equation:

$$\text{RMS threshold (VRMS)} = \sqrt{\text{AES power (WRMS, 2-hour)} * \text{minimum impedance (ohms)}}$$

Where AES power (WRMS, 2-hour) is the free-air component power rating

If minimum impedance data is unavailable, use nominal impedance. If 2-hour AES power ratings are unavailable, use 2-hour IEC power ratings. For most applications, we recommend operating LevelMAX limiters in Auto mode so that peak thresholds are automatically calculated based on the RMS threshold and selected lowpass frequency (see 1.1).

**2.2 RMS Release Time****User-Defined Setting**

In Auto mode, the RMS release time is determined based on the HIGH PASS frequency that is defined in the CROSSOVER. In Advanced mode, the RMS release time can be set by the user.

### 3.0 LevelMAX Transducer Thermal Limiter

LevelMAX transducer thermal limiting is designed to protect transducers from long-term thermal damage by gradually adjusting the RMS threshold until the target long term thermal threshold voltage has been reached. The thermal limiter functions only when the RMS limiter is enabled and when the thermal voltage threshold is lower than the RMS threshold. On the main limiter panel, the thermal protection LED turns on once the thermal limiter is 0.75 dB into limit.

#### 3.1 Thermal Voltage

##### User-Defined Setting

The thermal voltage threshold should be set to correspond to the transducer or system's long-term (100-hour) power-handling rating. Refer to the appropriate JBL specification sheet, technical manual or product manual for 100-hour power ratings. To calculate the thermal voltage threshold in VRMS use the equation:

$$\text{Thermal threshold (VRMS)} = \sqrt{\text{power (WRMS, 100-hour)} * (\text{nominal impedance})}$$

Where power (WRMS, 100-hour) is the 100-hour power rating.

If 100-hour power-handling data is unavailable, set the 100-hour power rating to approximately 0.8 x 2-hour power rating.

#### 3.2 Time Constant

##### User-Defined Setting

The thermal-response time (time constant) is the length of time the average RMS signal falls above the thermal threshold voltage before limiting begins. When the threshold is exceeded for the defined thermal response time, the RMS threshold is lowered until the target thermal voltage has been reached.

**NOTE:** The thermal response time is not the time it takes to reach the target voltage, although the longer the thermal response time, the longer it takes to reach the target voltage. Thermal-response time is also dependent on the amount of gain reduction and the ratio between RMS and thermal thresholds. Thermal response time is transducer-dependent and should be based on the initial temperature rise of the transducer voice coil to protect it from thermal overload. If detailed transducer data is unavailable, the thermal response time should be left at its default value of 10 seconds.

### Output Level Panel

The Output Gain, Mute and Polarity for each output channel can be adjusted on the Output Level Panel, see **Figure 34**.

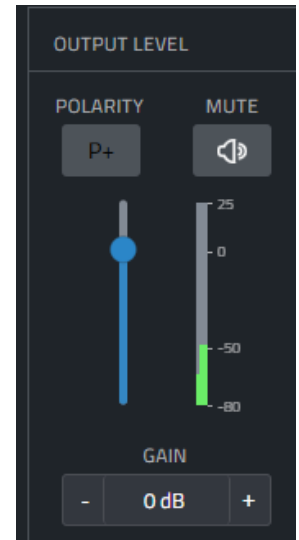

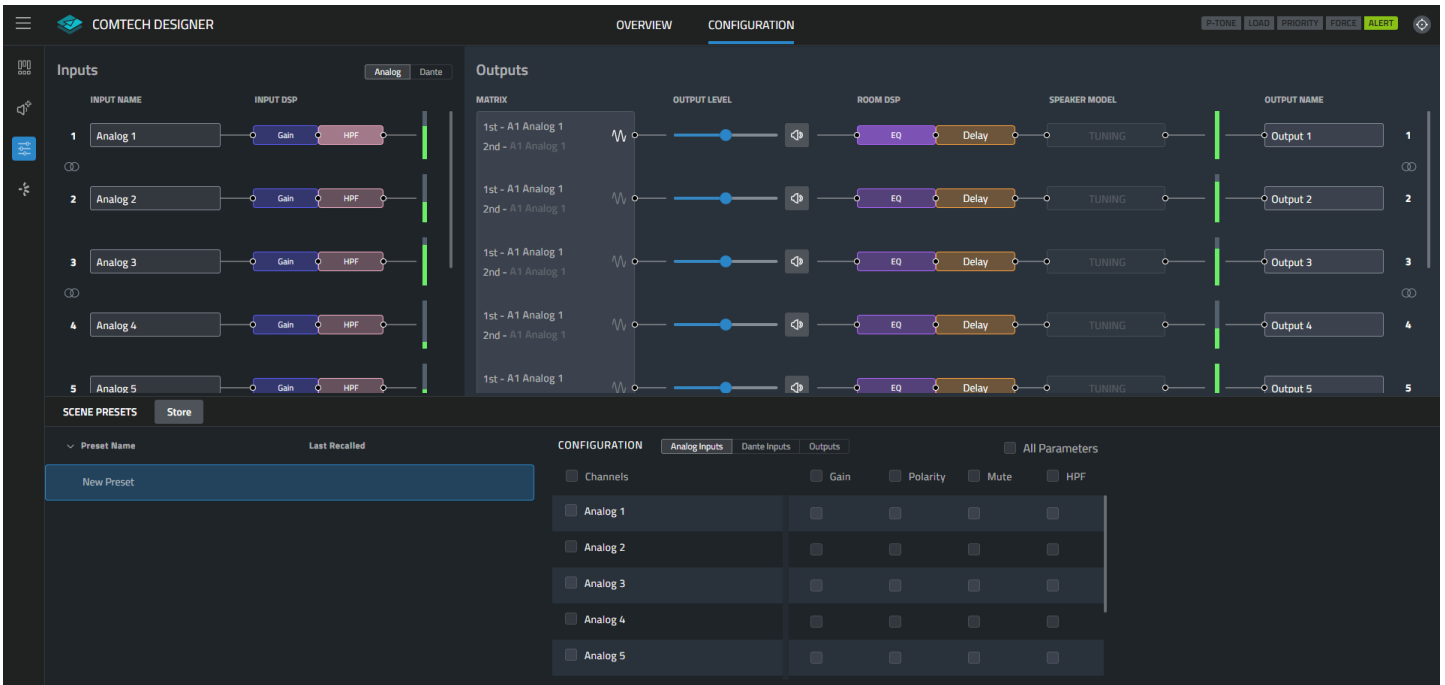

Figure 34: Output Level Panel

## WebUI – Using the Scene Presets

Clicking on the second icon  on the LEFT of the WebUI will bring up the Scene Presets Panel at the below half of the screen, see **Figure 35**.



**Figure 35: Scene Preset Panel**

On the Left of the Scene Presets Panel, you will be able to manage the Scene Presets such as Store, Import, Delete, Recall, Export, Update, Rename, etc... The ComTech could store up to 40 Scene Presets.

On the Right of the Scene Presets Panel, you will be able to configure which channels, and what parameters will be recalled when the scene preset is being Stored. For Analog Inputs and Dante Inputs, you will be able to select the TRIM, Mute, and HPF, and for the Outputs, you will be able to select SOURCE, GAIN, MUTE, PEQ, DELAY, POLARITY, and TUNING. See **Figure 36**.

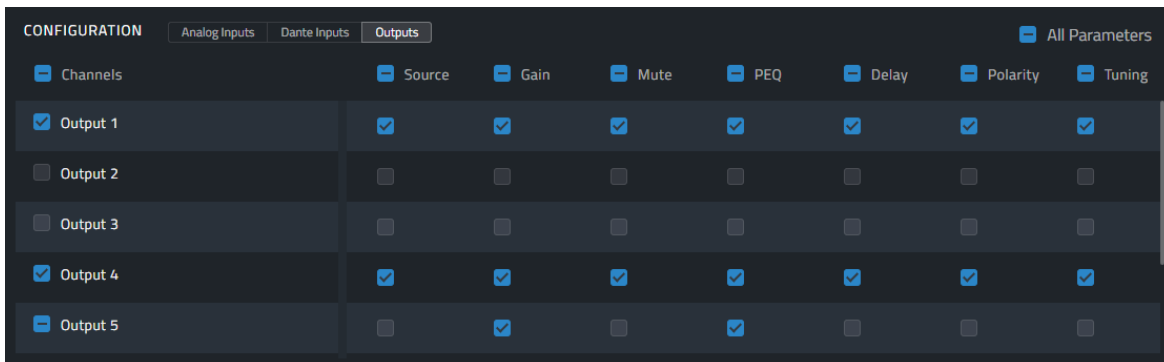

**Figure 36: Scene Preset Configuration – Output Selection**

## WebUI – Using the Scene Presets

### Managing the Scene Presets

Store and import a Scene preset can be performed by clicking the button located on the top of the Scene Presets Panel

Click on the icon  next to the actual Scene Preset will bring up a menu allow you to perform the following actions, see **Figure 37**.

- Recall
- Update
- Rename
- Delete
- Export

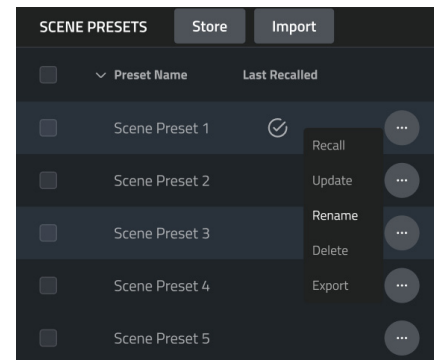

**Figure 37: Managing single Scene**

### Storing a Scene Preset

Storing a scene will store the current state of the parameter on the (Analog Input, Dante Input, Output) channels that are selected on the scene configuration section, once you click the STORE button, a window will pop-up to ask for confirmation and you can also edit the name for the preset. See **Figure 38**.

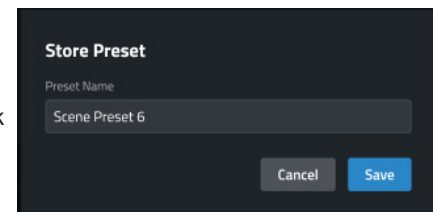

**Figure 38: Store Scene Preset**

### Importing a Scene Preset (available in future FW release)

Users can also import a Scene Preset or a list of Scene Presets from the Local PC. Click the Import button next to Store, a standard Local PC/Mac's window will pop-up to ask you to select the preset file/files to Import. Once the Scene Preset are successfully imported, there will be notification on the top of WebUI as shown in **Figure 39**.

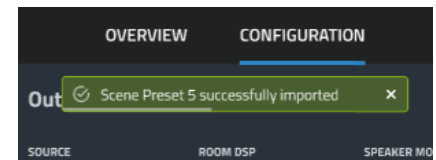
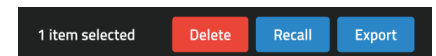

**Figure 39: Scene Preset Imported**

### Recalling a Scene Preset

To recall a scene preset, find the scene from the list of the left:

- 1) Click the "Check Box" on the left of the Scene Name, 3 action button will pop-up at the Bottom (Delete, Recall, Export), see **Figure 40**.
- 2) **OR** Click on the "..." icon next to the Scene name and click on RECALL from the menu.
- 3) Once you click the RECALL button, a window will pop-up to ask for confirmation. See **Figure 41**.



**Figure 40: 3 Action Buttons**

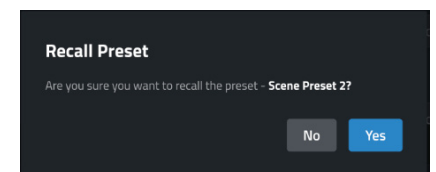
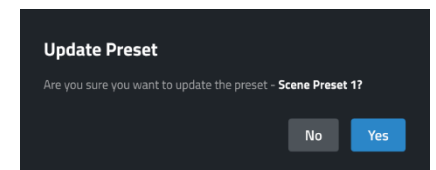

**Figure 41: Recall Scene Preset**

### Updating a Scene Preset

To update a Scene Preset:

- 1) First you recall the Scene Preset you would like to update, once the Scene Preset is recalled, there will be a "Check" icon next to the Scene Preset Name as shown in **Figure 37**.
- 2) Update the parameter value, or selection of channels and parameters.
- 3) Once you satisfy the changes you made, click on the "..." icon next to the Scene name and click on UPDATE from the menu, once you click the UPDATE button, a window will pop-up to ask for confirmation. See **Figure 42**.

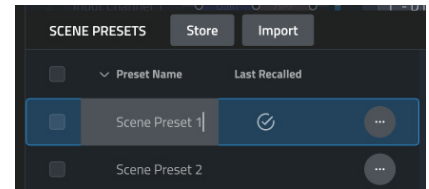

**Figure 42: Update Scene Preset**

## Renaming a Scene Preset

To rename a scene preset, find the scene from the list of the left:

- 1) Click on the name of the preset **OR** Click on the "..." icon next to the Scene name and click on RENAME from the menu.
- 2) You will be able to rename the Scene as shown in **Figure 43**.



**Figure 43: Renaming Preset**

## Deleting a Scene Preset

To delete a scene preset, find the scene from the list of the left:

- 1) Click the "Check Box" on the left of the Scene Name, 3 action button will pop-up at the Bottom (Delete, Recall, Export), see **Figure 44**.

**NOTE:** You can select multiple Scene Presets and perform deletion

- 2) **OR** Click on the "..." icon next to the Scene name and click on DELETE from the menu.
- 3) Once you click the DELETE button, a window will pop-up to ask for confirmation. See **Figure 45**.

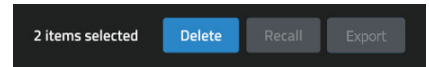

**Figure 44: 3 Action Buttons**

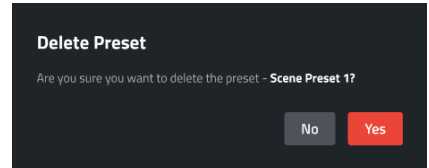
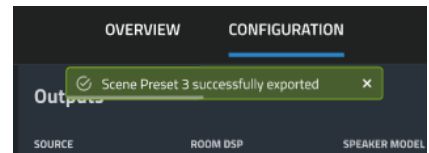

**Figure 45: Delete Scene Preset**

## Exporting a Scene Preset (available in future FW release)

To export a scene preset, find the scene from the list on the left:

- Click the "Check Box" on the left of the Scene Name, 3 action button will pop-up at the Bottom (Delete, Recall, Export), see **Figure 37**.
- **OR** Click on the "..." icon next to the Scene name and click on EXPORT from the menu.
- Once you click the EXPORT Button, a standard Local PC/Mac's window will pop-up to ask you to provide the file name of the Scene Preset to Export.
- Once the Scene Preset is successfully exported, there will be notification on the top of WebUI as shown in **Figure 46**.



**Figure 46: Export Scene Preset**

## WebUI – Using Pilot Tone and Load Monitoring

Clicking on the third icon on the LEFT of the WebUI will bring you to the Pilot Tone and Load Monitoring Page. Clicking any Input or Output will bring up the Pilot Tone and Load Monitoring Configuration Panel at the below half of the screen, see **Figure 47**.

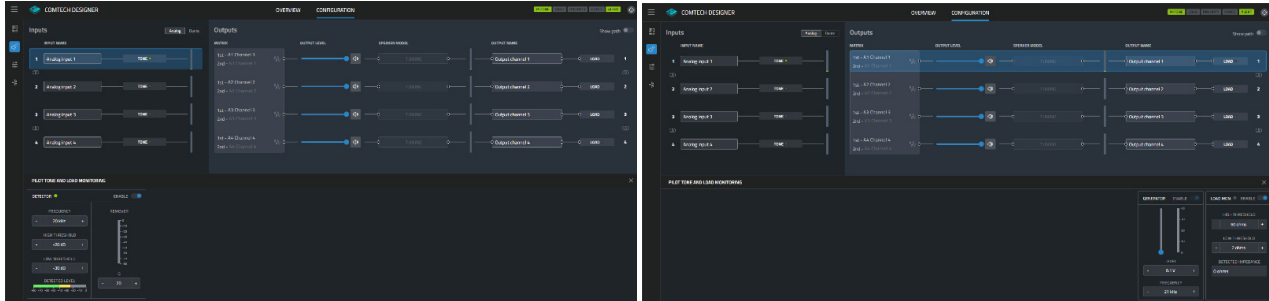

Figure 47: Pilot Tone and Load Monitoring Panel

### Configuring Incoming Pilot Tone Monitoring

Each input channel has an input pilot tone monitoring which allows users to detect and remove any incoming pilot tone. To enable the pilot tone detector, click ENABLE on the top right as shown in **Figure 48**.

#### Detector

##### Available Options / Parameters

- **Indicator LED**
  - GREY = Detector is OFF
  - GREEN = Detected Level is within the defined threshold range
  - RED = Detected Level is outside the defined threshold range
  - **Enable** (On / Off)

Turn On / Off the Pilot Tone Detector and Remove
- **Frequency** (10Hz – 22kHz)  
Selects the expected pilot tone frequency from the input source.
- **High Threshold** (-60dB to -10dB)  
Set the level for the high threshold, if the detected signal is higher than the threshold level, it will trigger a fault
- **Low Threshold** (-60dB to -10dB)  
Set the level for the low threshold, if the detected signal is lower than the threshold level, it will trigger a fault
- **Detected Level**  
Display the detected level of the incoming pilot tone.
- **Remover**  
To remove the incoming pilot tone from the signal
  - **Q** (0.1 – 32, increment of 0.05)  
Increase the Q value to remove the incoming pilot tone with minimum affect to the nearby frequency

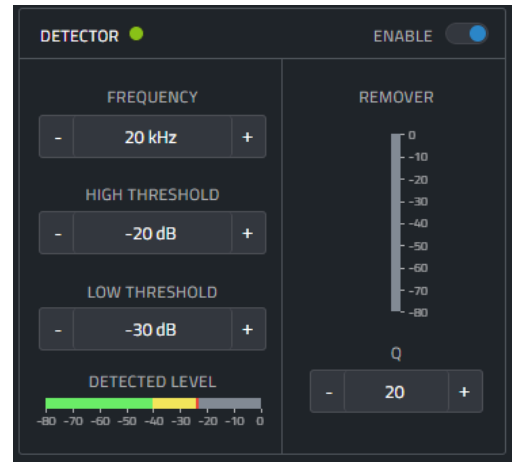

Figure 48: Pilot Tone Detector Panel

**NOTE:** When an input channel is set to Stereo, the Pilot Tone Monitoring on the Second Channel will follow the First Channel as User adjust the First channel, but User can adjust the Second Channel to different setting after adjusting the First Channel.

## Configuring Output Load Monitoring

Each output channel has an output load monitoring which allows users to detect the impedance of the output. In-order for the load monitoring to work, a pilot tone will be required to inject to the output. Enable the load monitoring, by clicking ENABLE on the top right as shown in **Figure 49**, the Generator will enable with the load monitoring.

### Generator

#### Available Options / Parameters

- **Enable** (On / Off)  
Turn On / Off the output signal generator
- **Level** (0.1 to 5 Vrms, increment of 0.1V)  
Set the level of the output pilot tone
- **Frequency** (10Hz to 22kHz, increment of 1Hz)  
Set the frequency for the output pilot tone

### Load Monitor

#### Available Options / Parameters

- **Indicator LED**
  - GREY = Load Monitoring is OFF
  - GREEN = Detected impedance is within the defined threshold range
  - RED = Detected impedance is outside the defined threshold range
- **Enable** (On / Off)  
Turn On / Off the Load Monitoring
- **High Threshold** (0.1Ω to 500Ω)  
Set the impedance for the high threshold, if the detected impedance is higher than the threshold impedance, it will trigger a fault
- **Low Threshold** (0.1Ω to 500Ω)  
Set the impedance for the low threshold, if the detected impedance is lower than the threshold impedance, it will trigger a fault
- **Detected Impedance**  
Display the detected impedance of the output channel.

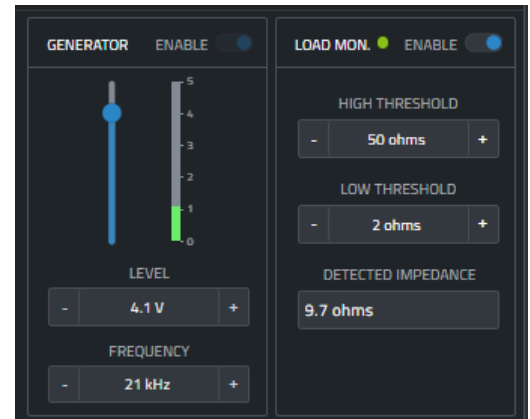
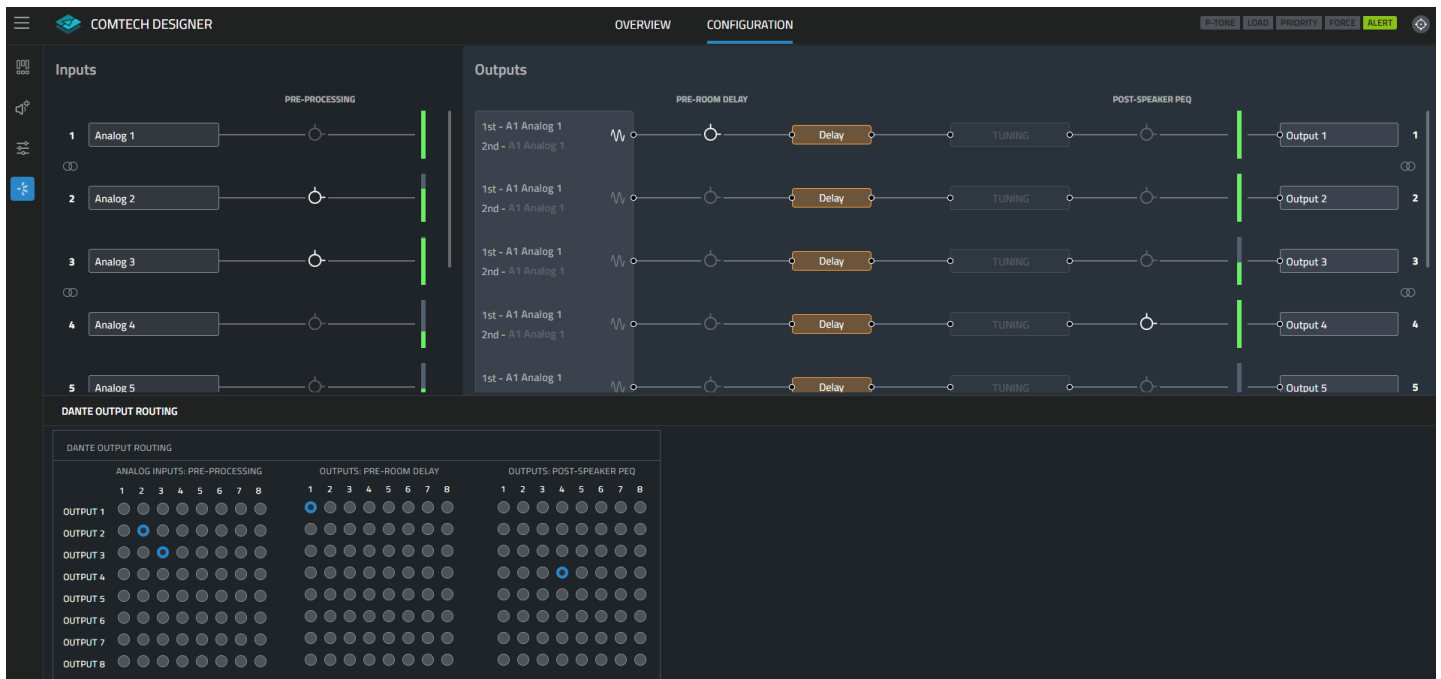

**Figure 49:** Load Monitoring Panel

**NOTE:** When an output channel is set to Stereo, the Load Monitoring on the Second Channel will follow the First Channel as User adjust the First channel, but User can adjust the Second Channel to different setting after adjusting the First Channel.

## WebUI – Dante Output Patching

Clicking on the fourth icon  on the LEFT of the WebUI will bring up the Dante Output Patching Panel at the below half of the screen, see **Figure 50**.



**Figure 50: Dante Output Patching**

There are 3 points on the signal path that can patch to Dante Output:

- Analog Input – Pre-Processing
- Output - Pre-Room Delay
- Output - Post-Speaker PEQ

To do a patch, simply click on the Matrix shown in **Figure 50**.

## WebUI – Hamburger Menu

There are more non-Audio related settings located in the Hamburger Menu, to open the menu click on the  button located on the top right, see **Figure 51**.

Under the Hamburger Menu, there are 7 items:

- Login (when Access Control is Enabled and Logout)
- Logout (when Access Control is Enabled and Login)
- GPIO Setting
- System Settings
- Device Settings
- Export (available in future FW release)
- Import (available in future FW release)

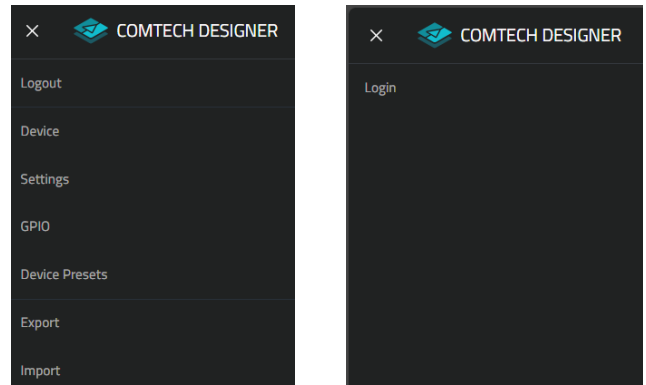

**Figure 51:** *Hamburger Menu*

### Using GPIO Control Port

ComTech D-Series amplifiers come with 4 GPI on the 2ch and 4ch, and 8 GPI on the 8ch. The GPI has multiple functions and uses, which include preset / source selection, gain control, among others. It also comes with a Fault Relay Output Port to report faults such as (AC Power, Power Supply, Thermal, Pilot Tone and Load Monitoring)

#### Hardware Specification

Inputs are capable of either binary or analog control of a state variable (SV) within the amplifier. Outputs are Relay.

GPI Control port pinout descriptions:

##### Connector 1

- PIN 1:** Common Ground (*not in use*)
- PIN 2:** Control Input 1 GND
- PIN 3:** Control Input 2 GND
- PIN 4:** Control Input 3 GND
- PIN 5:** Control Input 4 GND
- PIN 6:** Common +5V

##### Connector 2 (for 8ch version)

- PIN 1:** Common Ground (*not in use*)
- PIN 2:** Control Input 5 GND
- PIN 3:** Control Input 6 GND
- PIN 4:** Control Input 7 GND
- PIN 5:** Control Input 8 GND
- PIN 6:** Common +5V

Relay Output port pinout description:

- NC:** Normally Closed
- COM:** Common
- NO:** Normally Opened

**NOTE:** The relay could handle up to 30VDC 1A.

## Connecting BSS AC-V and AC-5S

The AC-V and AC-5S have 2 terminals: one which carries the voltage for source or level control and one for Control Port GND. **Figure 52** shows how a single controller would be connected to the GPI ports for control over port 1.

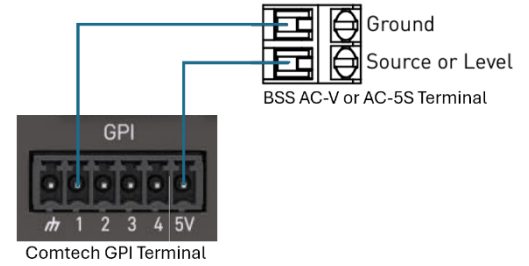

**Figure 52:** AC-V / AC-5S Connection Diagram

## Configuring the GPI Control Port

To access GPI configuration, click on the Hamburger menu and click GPIO will bring you to the GPIO configuration page, see **Figure 53**. To go back to the Overview or Configuration Page, click the OVERVIEW or CONFIGURATION on the top.

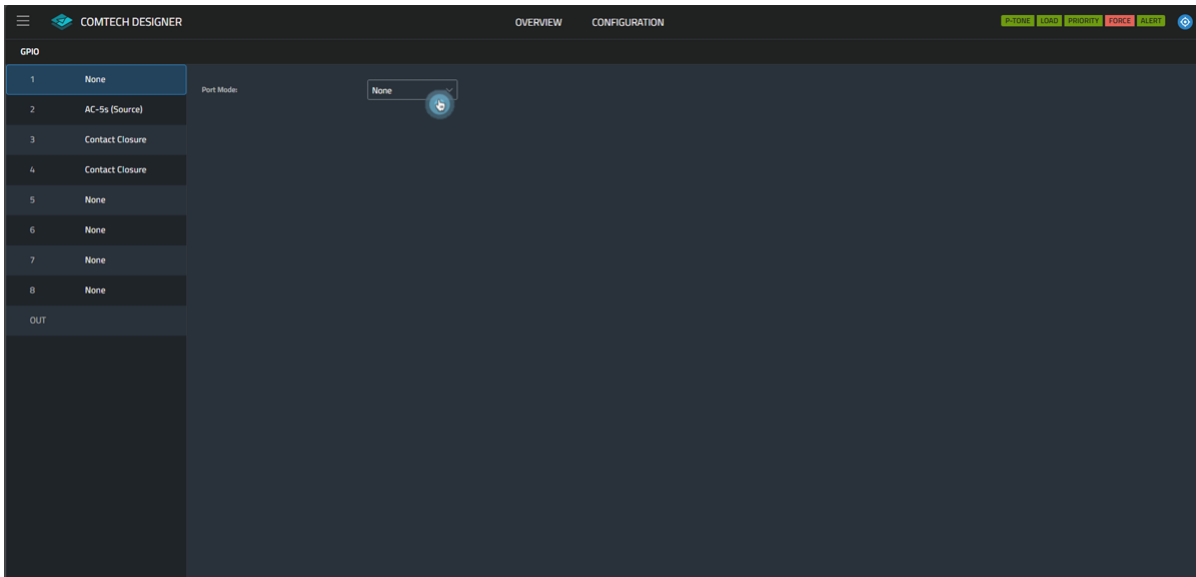
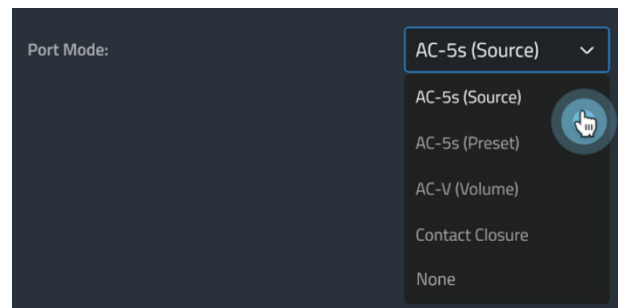

**Figure 53:** GPIO Configuration Page

The control port selection is located on the left, and the configuration of each port is located on the right. There are 4 ports mode to choose from for each port. To select port mode, click on the drop-down menu as shown in **Figure 54**.

Mode:

- AC-5s (Source)
- AC-5s (Preset)
- AC-V (Volume)
- Contact Closure
- None



**Figure 54:** Port Mode

### Configuring AC-5s (Source)

Using BSS AC-5s analog Control controller as a 5 positions Source selector. Once AC-5s (Source) is selected, the configuration will change as shown in **Figure 55**.

Users can assign multiple output channels to the same AC-5s Source selector, simply by checking the box next to the output channel. If the output channel is stereo linked, a stereo linked icon will appear between the stereo pair, and the right channel will automatically select if the left channel is selected.

There are 5 drop-down menus that allow users to assign the source to the different button on the AC-5s.

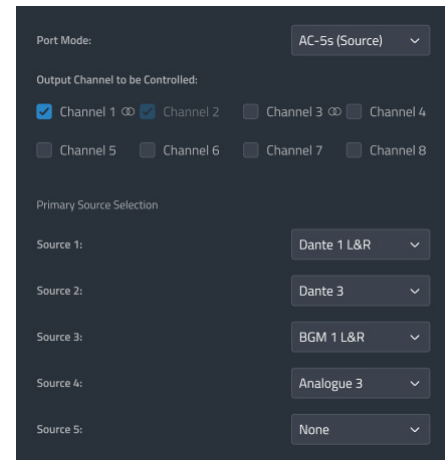
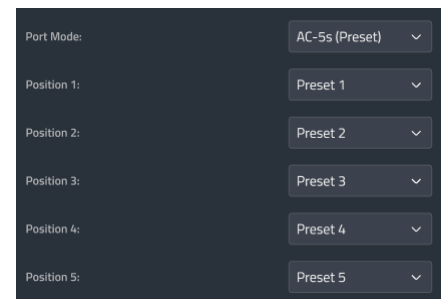

**Figure 55: AC-5s (Source)**

### Configuring AC-5s (Preset)

Using BSS AC-5s Analog Controller as 5 positions Preset selector. Once AC-5s (Preset) is selected, the configuration will change as shown in **Figure 56**.

User can assign different Scene Preset to the different button on the AC-5s.



**Figure 56: AC-5s (Preset)**

### Configuring AC-V (Volume)

Using BSS AC-V analog Volume controller as a volume control. Once AC-V is selected, the configuration will change as shown in **Figure 57**.

Users can assign multiple output channels to the same AC-V Volume controller, simply by checking the box next to the output channel #. If the output channel is stereo linked, a stereo linked icon will appear between the stereo pair and the right channel will automatically select when the left channel is selected.

Users can set the minimum level and the maximum level of the volume control by adjusting the Lower and Upper Limit on this screen.

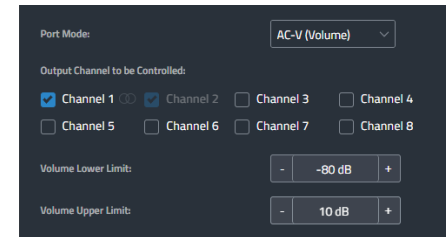

**Figure 57: AC-V (Volume)**

### Configuring Contact Closure

In Contact Closure mode, users can define behavior of the GPI.

#### Available Options / Parameters

- Trigger:
  - Assign which function to be trigger for this Contact Closure, see **Figure 58**
    - None
    - Mute All (Enable / Disable the Mute for all output channels via Contact Closure)
    - Sleep (Put the device into GPI Sleep via Contact Closure)
    - Scene Recall (Recall a Scene via Contact Closure)

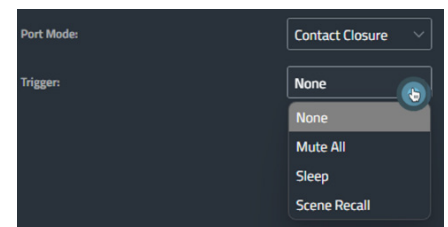
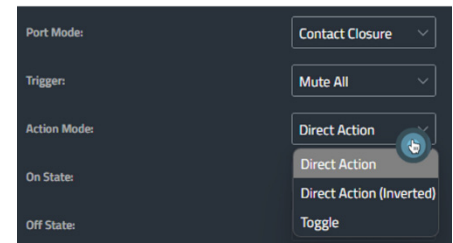

**Figure 58: Contact Closure - Trigger**

**NOTE:** Only use GPI 1 for Sleep

## WebUI – Hamburger Menu

- Action Mode:
  - There are 3 types of action mode available, see **Figure 59**.
    - Direct Action (*When the port is active, it goes to On State*)
    - Direct Action Inverted (*When the port is active, it goes to Off State*)
    - Toggle (*Each time the port is activated, it will change to alternate state*)
  - Not all action modes are available to all functions
    - In Mute All Mode (Direct Action | Direct Action Inverted | Toggle)
    - In Sleep Mode (Direct Action ONLY)
    - In Scene Recall Mode (Direct Action | Toggle)
- On State:
  - This defines the action to be taken during On State. In some functions the action is fixed, see **Figure 60**.
    - In Mute All Mode (Mute All Enabled)
      - In Sleep Mode (Sleep Enabled)
    - In Scene Recall Mode
      - None (no action to be taken)
      - Pick from the list of Scene Presets (to recall the Scene Preset during On State)
- Off State:
  - This defines the action to be taken during Off State. In some functions the action is fixed.
    - In Mute All Mode (Mute All Disabled)
    - In Sleep Mode (Sleep Disabled)
    - In Scene Recall Mode
      - None (no action to be taken)
      - Pick from the list of Scene Presets (to recall the Scene Preset during Off State)



**Figure 59:** Contact Closure – Action Mode

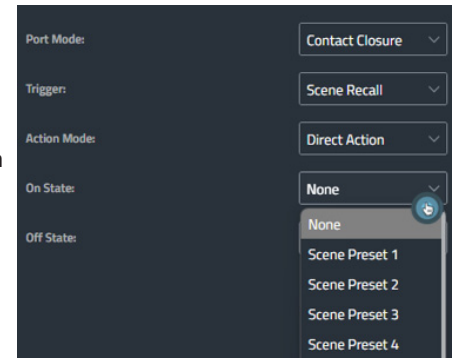

**Figure 60:** Contact Closure – ON/OFF State

## Configuring the Relay Output Control Port

ComTech D-Series amplifiers come with 1 Relay Output Control Port. Depending on the external system that users connected to, users can choose to connect NC (normally closed) and Com (common), or NO (normally opened) and Com (common) to the external system. Users could choose any or all listed faults to trigger the output relay. See **Figure 61**.

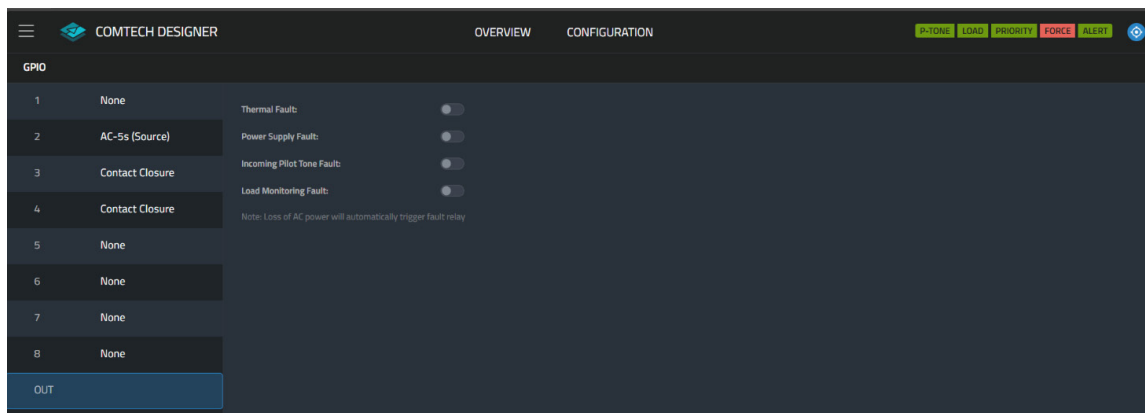
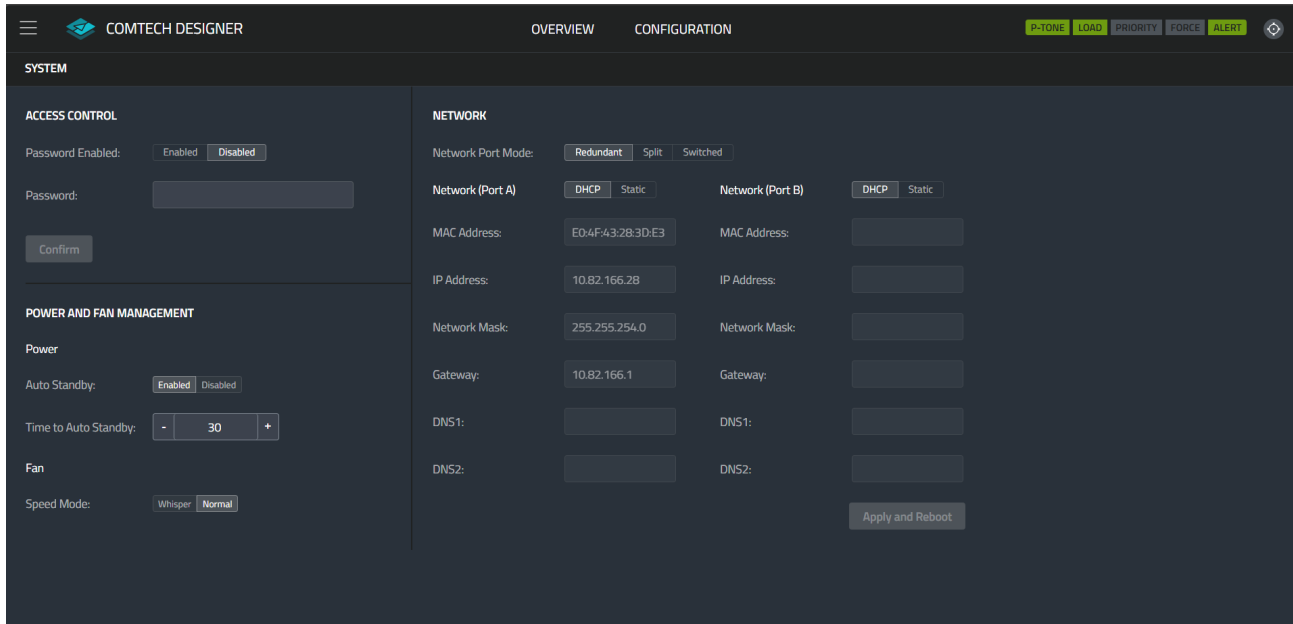

**Figure 61:** Relay Output Configuration

NOTE: Normally Closed –when there are no faults, the NC and Com is Closed.  
 Normally Opened –when there are no faults, the NO and Com is Closed.  
 By default, loss of AC Power will automatically trigger the relay.  
 \*\* The Relay will output fault when the amplifier is in Sleep mode.

## Using System Settings

System settings include Access Control, Power and Fan Management and Network setting. See **Figure 62**.



**Figure 62: System Settings**

### Setting up Access Control

Access Control all User/Install to lock the WebUI and leave the Operator with only access to the Overview Page for simple control such as Source selection, Volume and Mute control for each output.

To enable Access Control:

1. Select "Enabled"
2. Enter the Password
3. Click "Confirm"

Once User click Confirm, a Login Page will appear see **Figure 63**. Enter the "Password" to Login.

To Logout, click Hamburger Menu and Click Logout as shown in **Figure 51**.

Once Logout, User will only have access to the Overview Page, other pages such as the Configuration, the Side Rail, and the Hamburger Menu will be hidden, to access these pages, click the Hamburger Menu and Click Login see **Figure 51**.

**NOTE:** Once User has Login, the WebUI will remain unlock until the Logout or the WebUI is closed.

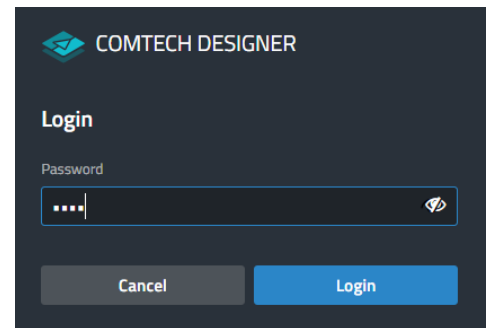

**Figure 63: Login Page**

## Power and Fan Management

### Auto Standby:

The ComTech D-Series will go to Auto Standby when there is no audio signal coming in for a certain amount of time, and the unit will wake once signal is detected. Users can Enable/Disable the Auto Standby. When the Standby Mode is enabled, users can set the time of idle before the amplifier enter the Auto Standby mode.

**NOTE:** When Auto Standby is disabled, the power consumption of the amplifier at idle will increase to ~8.2W – 15.5W depends on the model.

### Fan Speed Mode:

- Whisper Mode** - The RPM of the fan is on a limiter to keep the noise down; Thermal limiter threshold decreases when the fan reached target RPM, and the Power / Audio level output will reduce.
- Normal Mode** - The fan can drive up to maximum RPM depending on the temperature of the amplifier.

## Configuring the Network

Network settings can be configured from either the WebUI or from the AVX Manager software application. DHCP is enabled by default, allowing the ComTech D-Series amplifiers to automatically obtain an IP address when connecting to an Ethernet switch or router with an active DHCP server, or when using Auto-IP. There are 2 network ports on the ComTech D-Series amplifier, and these ports can be configured into different modes, split mode is selected by default.

### Available Options / Parameters

- Network Port Mode:
  - **Split Mode (Default)**
    - Port A= Control Only
    - Port B= Dante Only
  - **Redundant Mode**
    - Port A= Control + Dante Primary
    - Port B= Dante Secondary
  - **Switched Mode** (must use with router w/DHCP Server)
    - Port A= Control + Dante
    - Port B= for Daisy Chain
- Network: (DHCP / Static)
  - "DHCP" to allow the amplifier to automatically obtain an IP address from a DHCP server or via Auto-IP.
  - "Static" to manually configure the amplifier's network settings.
- IP Address
  - Allows for viewing and editing of the amplifier's IP address
- Network Mask / Subnet Mask
  - Allows for viewing and editing of the amplifier's Network Mask / Subnet Mask
- Gateway
  - Allows for viewing and editing of the gateway address, if required to access the network. If using a router, the gateway address will typically be the router address.
- DNS 1 / DNS 2
  - Allows for viewing and editing of the DNS address

Once the network setting has been set, click "Confirm" at the bottom of the screen for the changes to take effect.

## Using Device Setting

In the device setting page, users can view the device information, update firmware, and do factory reset of the amplifier. See *Figure 64*.

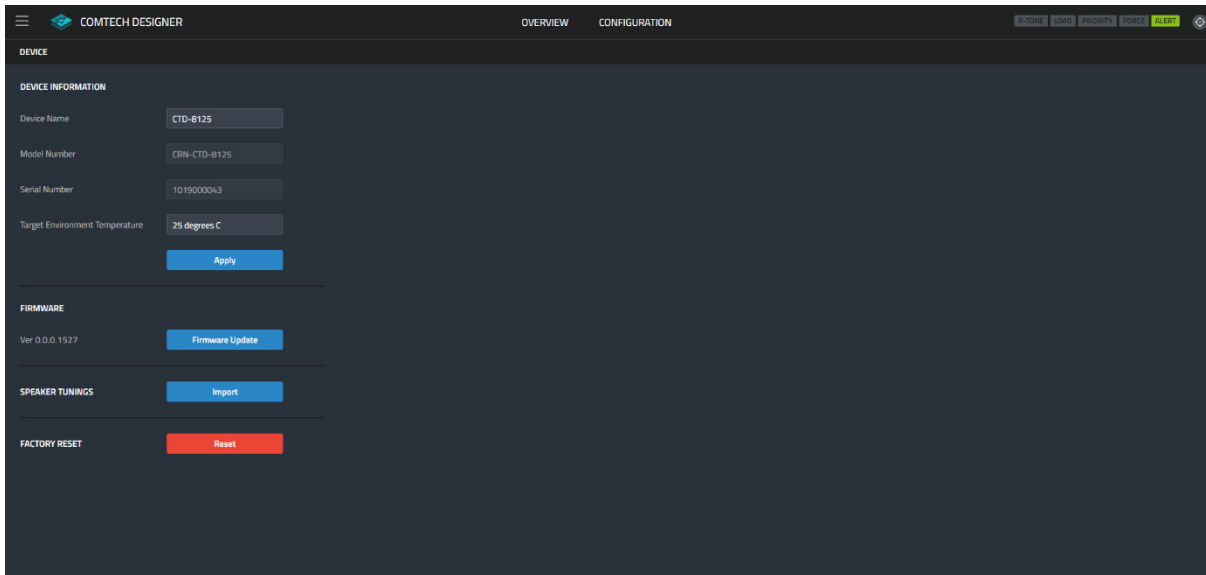

**Figure 64:** Device setting Page

### Device information

Device information contains information such as Device Name, Model Number, Serial Number, MAC Address, H-Control ID, and Target Environment Temperature. Most of these are read only except for the following:

- Device Name
  - Users could change the name of the device for easy identification.
- Target Environment Temperature
  - Temperature has an effect of the Speed of Sound, and adjusting the temperature here will affect the time delay conversation from Meter/Feet to milliseconds within the amplifier.

### Firmware

It displays the current firmware version on the amplifier, and the user could update the firmware here.

### Speaker Tunings

When there are new JBL Speaker Tunings published on JBL Website, users can download them to the Local PC and Import them here.

### Factory Reset

The Factory Reset allows a ComTech D Series amplifier to be reverted back to its factory default state. When initiated, the Factory Reset will perform the following tasks:

- Erase all user presets (this includes all user DSP and configuration settings)
- Reset all system settings

**Warning!** All user presets will be permanently deleted, and all settings reverted to their factory default state. This process is irreversible. If you have any user presets you wish to keep, they should be backed up before performing the Factory Reset. See ["Using Export / Import"](#) for more information.

### Using Export / Import (available in future FW release)

#### Export

Export Device allows configuration, DSP, channel assignment, gains, scene presets, as well as other settings to be stored for later imports. The (\*.CTD Series.Device) file will be stored at the default download folder, and this file can be used as a setting backup or if the user wishes to duplicate all the settings to another ComTech D Series amplifier.

#### Import

When importing a device, the WebUI will ask if you want to clone the device, see **Figure 65**.

Clone the Device:

- All settings including Network Settings, Device ID, will get loaded to the device. It is ideal for amplifier replacement when there is fault on the amplifier or restore some old setting from the previous export.

Not Cloning the Device:

- All settings excluding Network Settings and Device ID will get loaded to the device. It is ideal when you would like to duplicate the settings from one amplifier to another amplifiers.

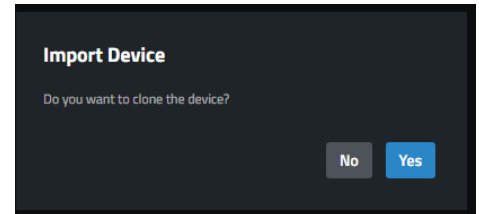

**Figure 65:** *Import Device*

## WebUI - Alert Page

Users can check the real-time Alerts and Event Logs from the Alert Page. To open the Alert Page, click the ALERT icon on the top right corner. See **Figure 66**.

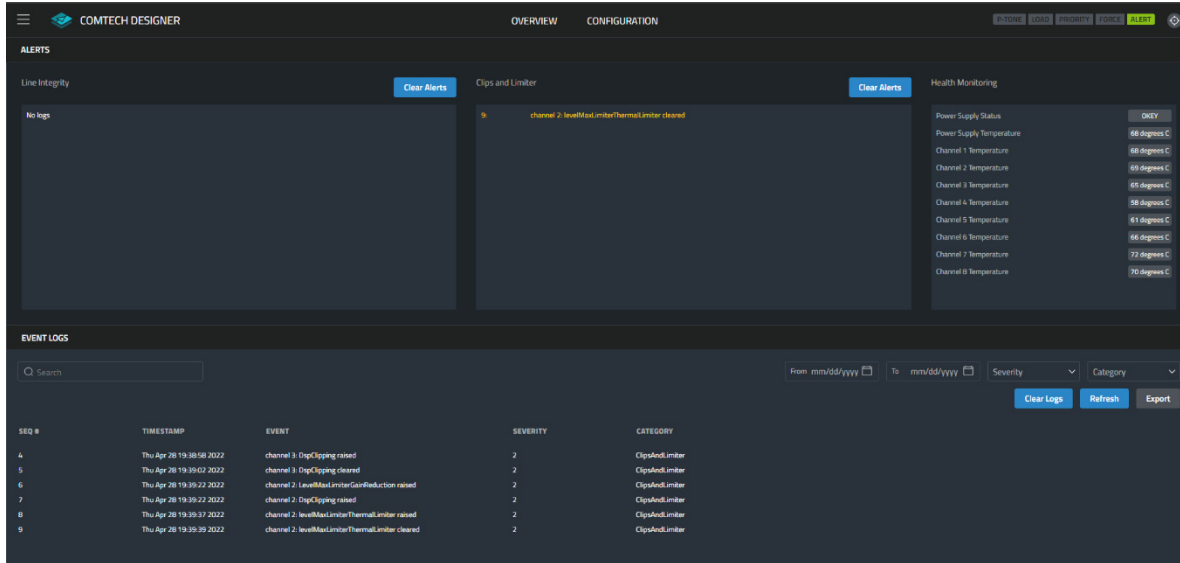

**Figure 66: Alert Page**

### Alerts

There are 3 types of alerts that users can monitor real-time, Line Integrity, Clips and Limiters and Amplifier Health Monitoring.

#### Line Integrity

Any events or alerts related to Line Integrity (including Incoming Pilot Tone Monitoring and Output Load Monitoring) will be displayed under this section. Once the issue has been resolved, the alert will be cleared, but these events will be recorded in the Event Log.

#### Clip and Limiter

Any errors or alert related to Input Clipping, Output Clipping, LevelMax Gain Reduction, and LevelMax Thermal Threshold Limiter will be displayed under this section. Once the event has been resolved, the alert will be cleared, but these events will be recorded in the Event Log.

#### Health Monitoring

Power Supply Status, Power Supply Temperature, and Temperature of each amplifier output channel can be viewed under this section.

### Event Logs

Event Logs shows events that have occurred on the ComTech D Series Amplifier. The log may be utilized by the amplifier to perform certain operations. You can also use logs for troubleshooting.

#### Sequence (SEQ #)

A sequence number designates the order of occurrence of said event in relation to other events.

#### TIMESTAMP

The time of the event occurred. The time zone is based on UTC.

#### EVENT

Description of the event occurred.

## SEVERITY

Priority of the event occurred.

Priority ID	Name	Description
0	Debug	debug log is intended for engineering use
1	Information	This system operates within all standard parameter ranges. This is information only.
2	Warning	Any condition in which the device is working as intended, but the working parameters are getting close to the limit of failure of the HW. The device can recover from a warning.
3	Fault/Error	Any condition in which the device is not working as intended and the device cannot recover from this condition on its own. A reboot might help the device recover functionality or a service is needed to restore functionality.
4	Audit	

## CATEGORY

The category of the event.

Line Integrity – events that occurs in relation to Pilot Tone & Load Monitoring

Clip and Limiting – events that occur in relation to channel clipping and Limiting

Device – events that occur within or in relation to a device

Hardware Status – events that in relation to hardware status

Application – events that in relation to the WebUI or AVX Manager

Access Control – events that in relation to Login, Logout, Password changed.

## Clear Alerts / Logs

This clears the alerts from the screen and clears the logs from the device.

## Refresh

Refresh will retrieve the logs from the device.

## Export

The logs can be exported to a file.

## Application Examples

### Power Share across 2 channels

On the 2 channels version of ComTech, the power can only be shared across 2 channels, and the maximum power is 250W. As long as the total power drawn for the 2 channels is within the 250W limit, the system will be able to handle. See **Figure 67**.

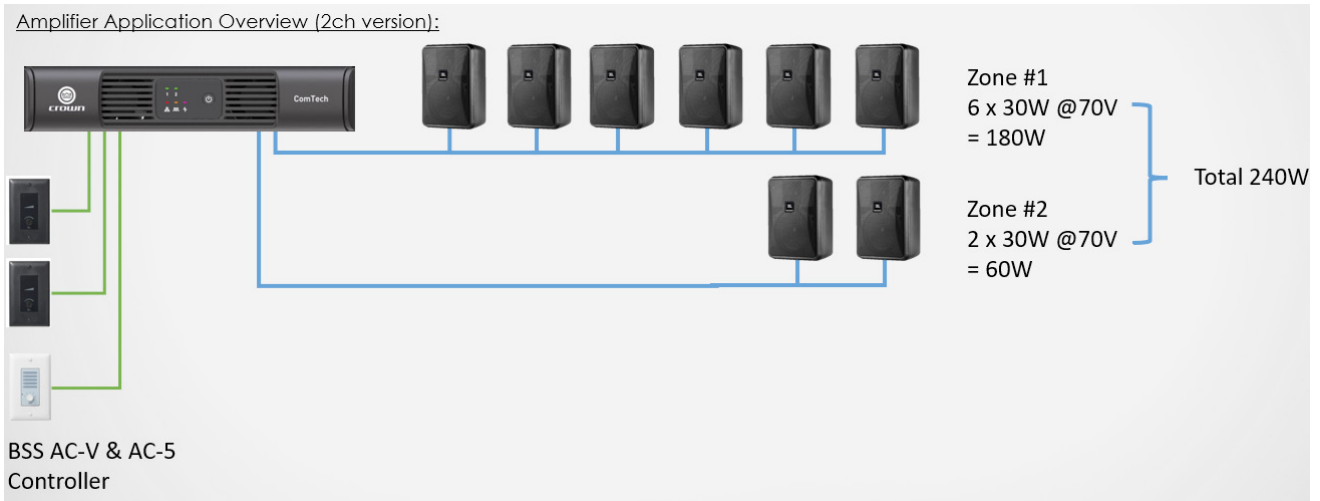

Figure 67: 2-ch Power Share Application Sample

### Power Share across 4 channels

On the 4 channels and the 8 channels version of ComTech, the power can be shared across 4 channels with the maximum power is 500W per 4 channels. As long as the total power drawn for the 4 channels is within the 500W limit, the system will be able to handle. The channels can be either Low-Z or Hi-Z. See **Figure 68**.

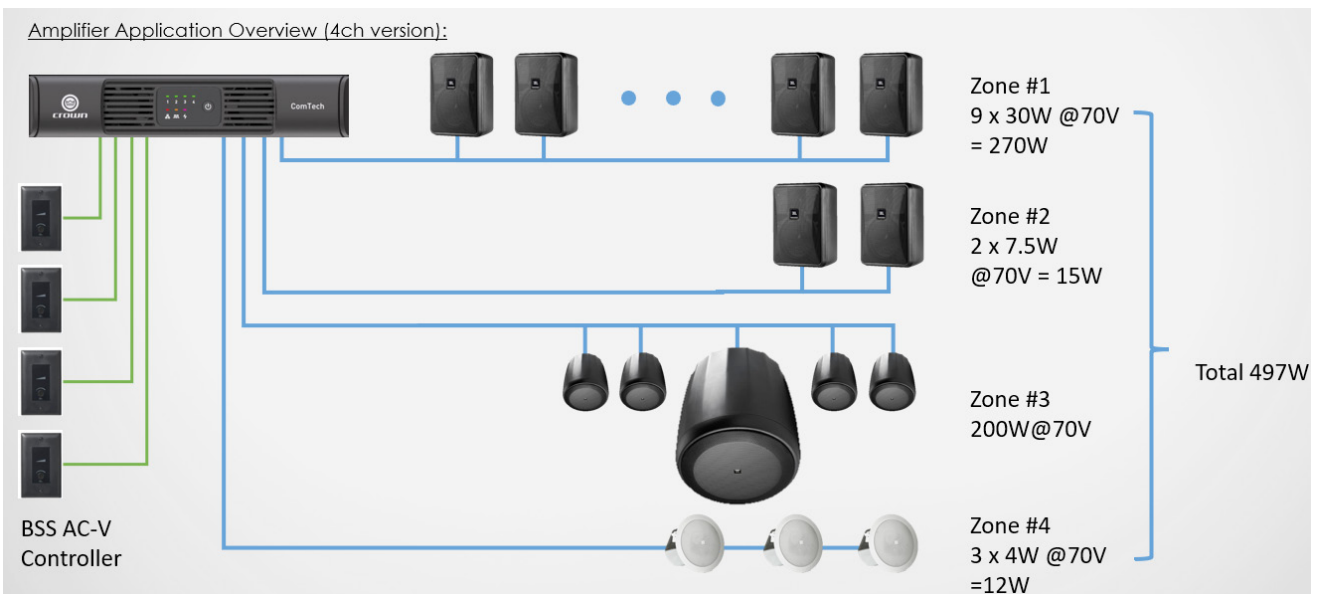

Figure 68: 4-ch Power Share Application Sample

## Network Modes

Users can use Split Mode with either 2 separate networks or 2 separate VLANs. See **Figure 69, 70**.

### Network Mode: Split Mode (2 Separated Networks)

- ComTech D Series Network Ports
- PORT A: HControl
  - PORT B: Dante

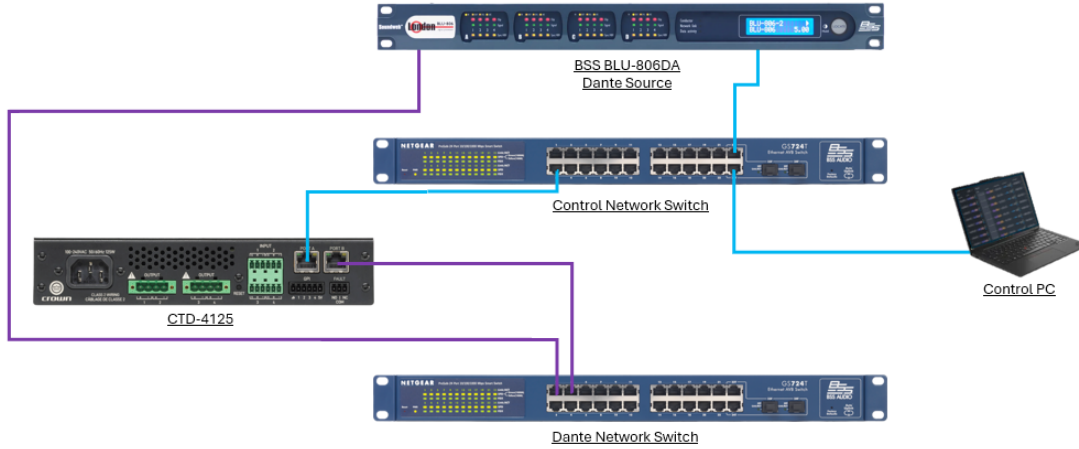
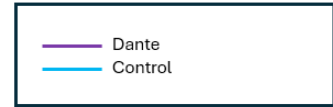

**Figure 69:** Split Mode with 2 Separated Networks

### Network Mode: Split Mode (Single Network – 2 VLANs)

- ComTech D Series Network Ports
- PORT A: HControl
  - PORT B: Dante

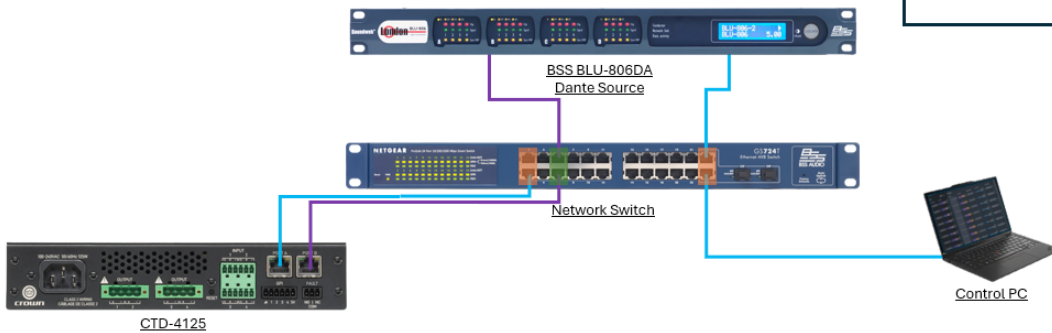
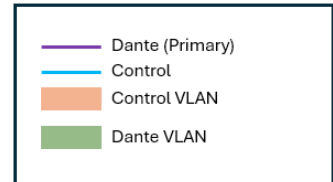
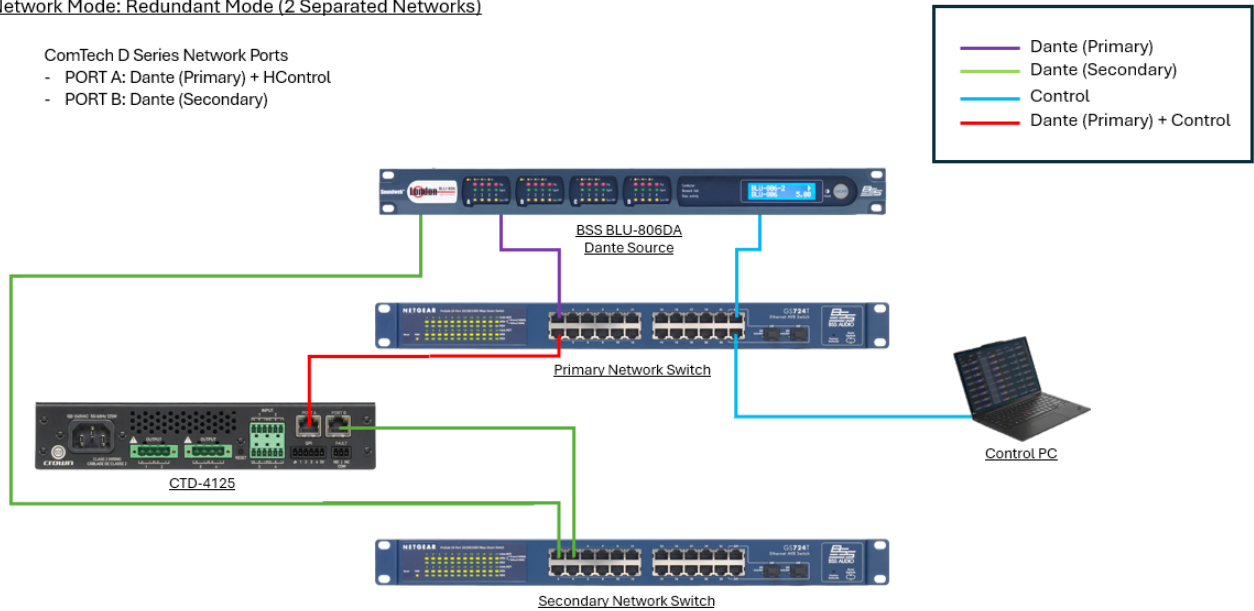

**Figure 70:** Split Mode with 2 Separated VLANs

Users can use Redundant Mode with either 2 separate networks or 2 separate VLANs. See **Figure 71, 72.**

Network Mode: Redundant Mode (2 Separated Networks)

- ComTech D Series Network Ports
- PORT A: Dante (Primary) + HControl
  - PORT B: Dante (Secondary)



**Figure 71: Redundant Mode with 2 Separated Networks**

Network Mode: Redundant Mode (Single Network – 2 VLANs)

- ComTech D Series Network Ports
- PORT A: Dante (Primary) + HControl
  - PORT B: Dante (Secondary)

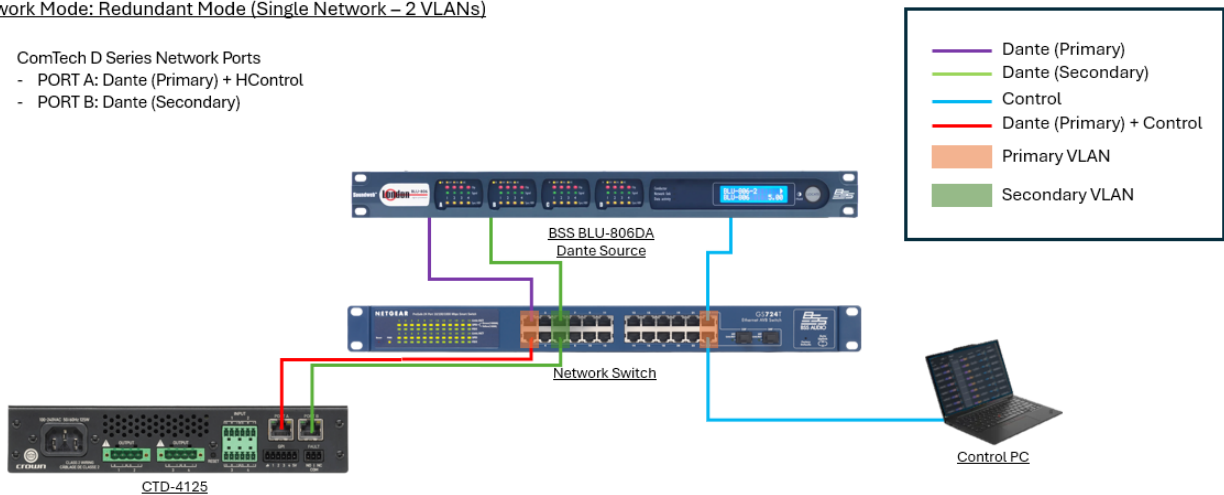

**Figure 72: Redundant Mode with 2 Separated VLANs**

Users can use Switched Mode to Daisy-chain the ComTech D-Series Amplifier to reduce the number of Ethernet ports required from the Network Switch. See **Figure 73**.

**Network Mode: Switched Mode**

ComTech D Series Network Ports

- PORT A: Dante + HControl
- PORT B: Loop Thru

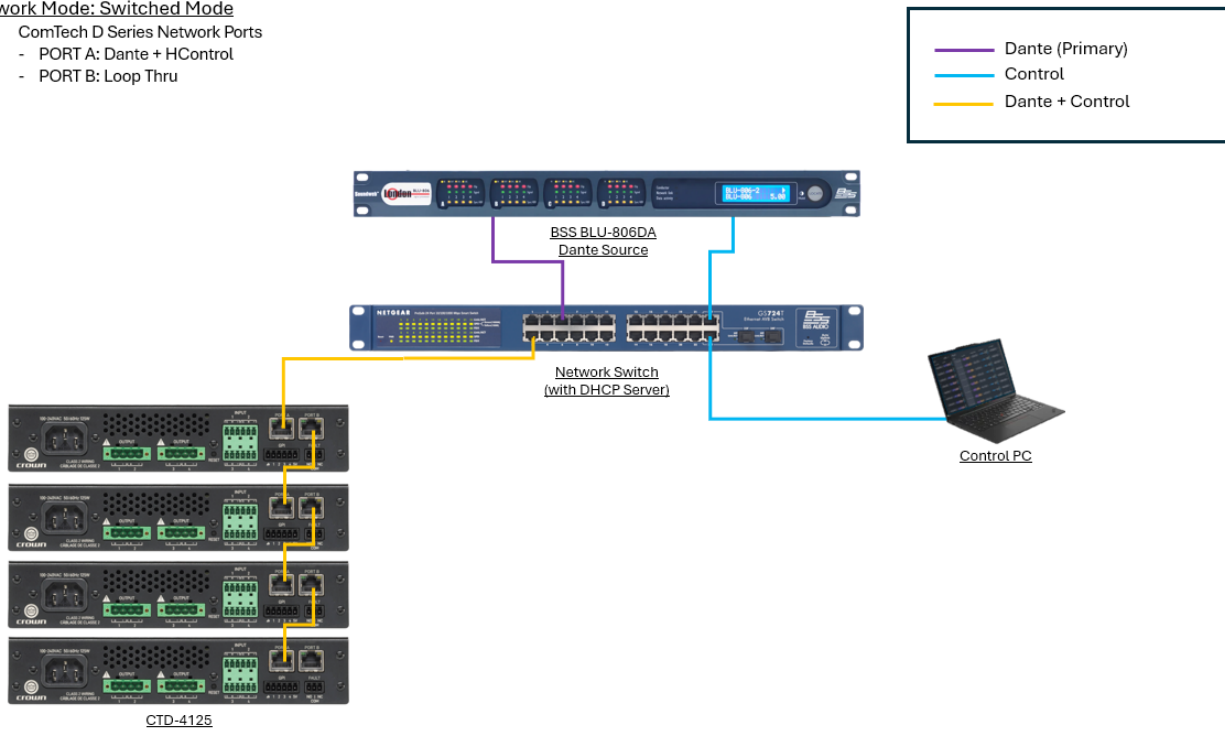

**Figure 73: Switched Mode**

**NOTE:** DHCP Server will be required in switched mode if running AUTO-IP.

**NOTE:** Recommended maximum 4 Daisy-Chain units.

## System Protection

### Faults

The amplifier will enter a fault state if it senses an unsafe condition. This protection is for both internal and external faults. In addition, be sure that the load connected to the amplifier is within the 4–8 $\Omega$  limit. If wiring is verified as correct and the fault condition persists, see "[Service](#)" for servicing information.

### Thermal Limit

If the amplifier becomes too hot for safe operation, the channel that is generating too much heat will be shut down until the temperature drops below the thermal limit. The front-panel thermal indicator will illuminate at 112 degrees Celsius, indicating the onset of compression affecting the audio signal. The amplifier will continue to run in this state until either the temperature is reduced to a safe operating range or, if the temperature continues to rise, the channel shuts off to protect itself above 118 degrees Celsius.

### Auto-Insertion High-Pass Filters

A 35Hz high-pass filter is inserted automatically when an output channel is configured for high-Z operation.

### Fan-Cooled Chassis

ComTech D Series amplifiers are cooled by quiet, variable-speed fans. The maximum fan noise level of a ComTech D Series amplifier is 48 dBA. The fans will pull air from the front of the amplifier to the rear of the amplifier.

The following fault conditions will cause the fan to turn on full speed:

- High-frequency fault
- DC fault
- Short-circuit fault
- Thermal fault
- Rail fault

### Universal Switching Power Supply

The ComTech D Series amplifiers incorporate a switching power supply designed for extremely high efficiency and high output power.

## Troubleshooting

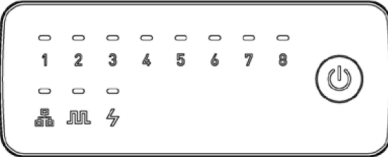
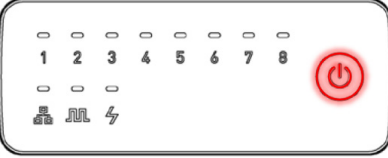
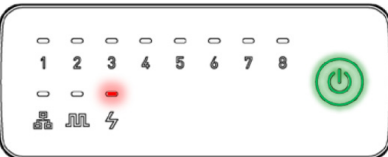
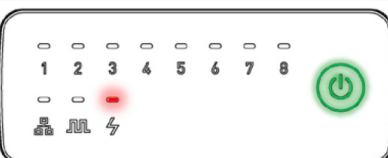
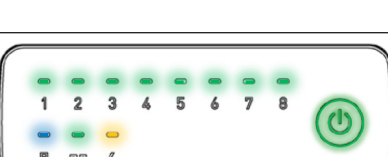
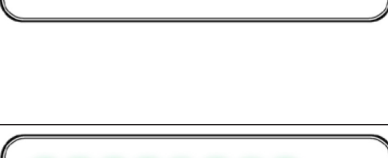
	<p><b>CONDITION:</b> <i>Power indicator off.</i></p> <p><b>POSSIBLE REASON:</b></p> <ul style="list-style-type: none"> <li>• The amplifier is not plugged in to the power receptacle.</li> <li>• The amplifier has lost AC Power.</li> </ul>
	<p><b>CONDITION:</b> <i>Power indicator is on RED.</i></p> <p><b>POSSIBLE REASON:</b></p> <ul style="list-style-type: none"> <li>• The Power Supply might be faulty. Disconnect the power cord and reconnect the power cord and powerup the amplifier. If the RED Power indicator remains after the power cycle, the unit should be serviced. See "<a href="#">Service</a>".</li> </ul>
	<p><b>CONDITION:</b> <i>Health indicator is on Flashing RED.</i></p> <p><b>POSSIBLE REASON:</b></p> <ul style="list-style-type: none"> <li>• There is an error related to Line Integrity, either there is an error on the incoming pilot tone, or output load monitoring. See "WebUI – Pilot Tone and Load Monitoring" page</li> </ul>
	<p><b>CONDITION:</b> <i>Health indicator is on Solid RED.</i></p> <p><b>POSSIBLE REASON:</b></p> <ul style="list-style-type: none"> <li>• There are Hardware Failure or Fault on Power Supply is detected. These conditions should all be checked and attempted to be resolved before the amp is shipped back for service. See "<a href="#">System Protection</a>" for more information on these protection features.</li> </ul>
	<p><b>CONDITION:</b> <i>Health indicator is on Solid AMBER.</i></p> <p><b>POSSIBLE REASON:</b></p> <ul style="list-style-type: none"> <li>• The amplifier is becoming too hot for safe operation. Allow amplifier to cool. Check for loads less than 4Ω and for excessive input levels. Check for proper ventilation and proper output mode (4/8Ω, 70V, 100V) setting. See "<a href="#">Proper Cooling</a>" for information on rack mounting and cooling. See "<a href="#">System Protection</a>" for detailed information on thermal limits. See "<a href="#">Configuring Output Mode</a>" for information on configuring the output mode.</li> </ul>
	<p><b>CONDITION:</b> <i>No sound, even though the Power LED is lit GREEN, and the level meters indicate the amp is sending an output signal.</i></p> <p><b>POSSIBLE REASON:</b></p> <ul style="list-style-type: none"> <li>• Speaker not connected. Power off the amplifier, disconnect the AC power cord, then verify speaker connection.</li> <li>• Open circuit due to speaker failure. From the front panel display, determine which channel has the short. Power down the amplifier then disconnect the AC power cable. Remove the shorted load from the channel (and possibly attached cables) and have it checked by a qualified technician. Reconnect the power cord and powerup the amplifier. If the shorted condition remains after the load is removed, the unit should be serviced. See "<a href="#">Service</a>".</li> </ul>

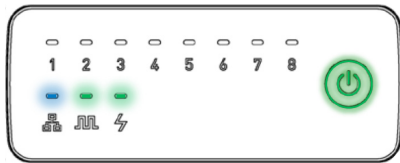

**CONDITION:** No output signal. Output signal indicator is not lighting, even though audio is being sent to the amplifier's input and the amp is powered on (GREEN Power indicator lit).

**POSSIBLE REASON:**

- Input or Output signal level is very low. Double check the gain structure of the system and ensure that the amplifier's input trim levels and output gain level are set accordingly.
- Input routing is not configured correctly for application. See "[Using Output Source Mixer Panel](#)".

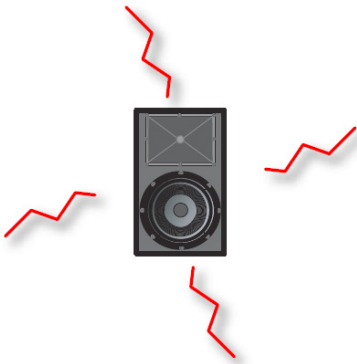

**CONDITION:** Distorted sound.

**POSSIBLE REASON:**

- Load is wired incorrectly, or Low-Z/Hi-Z mode is configured incorrectly – both should be verified. See "[Wiring Output Connectors](#)" and "[Configuring Output Mode](#)".
- Input is overloaded by a signal level that is too high. Turn down the amplifier input level controls or turn down the output of the source signal until the Clip Indicator goes out.

**NOTE:** If the signal sounds distorted even though the Clip Indicator is off, the signal may be distorted before it reaches the amplifier input. Check gain staging and output levels of the mixer or preamp.

# Signal Path Block Diagram

## Signal Path Block Diagram

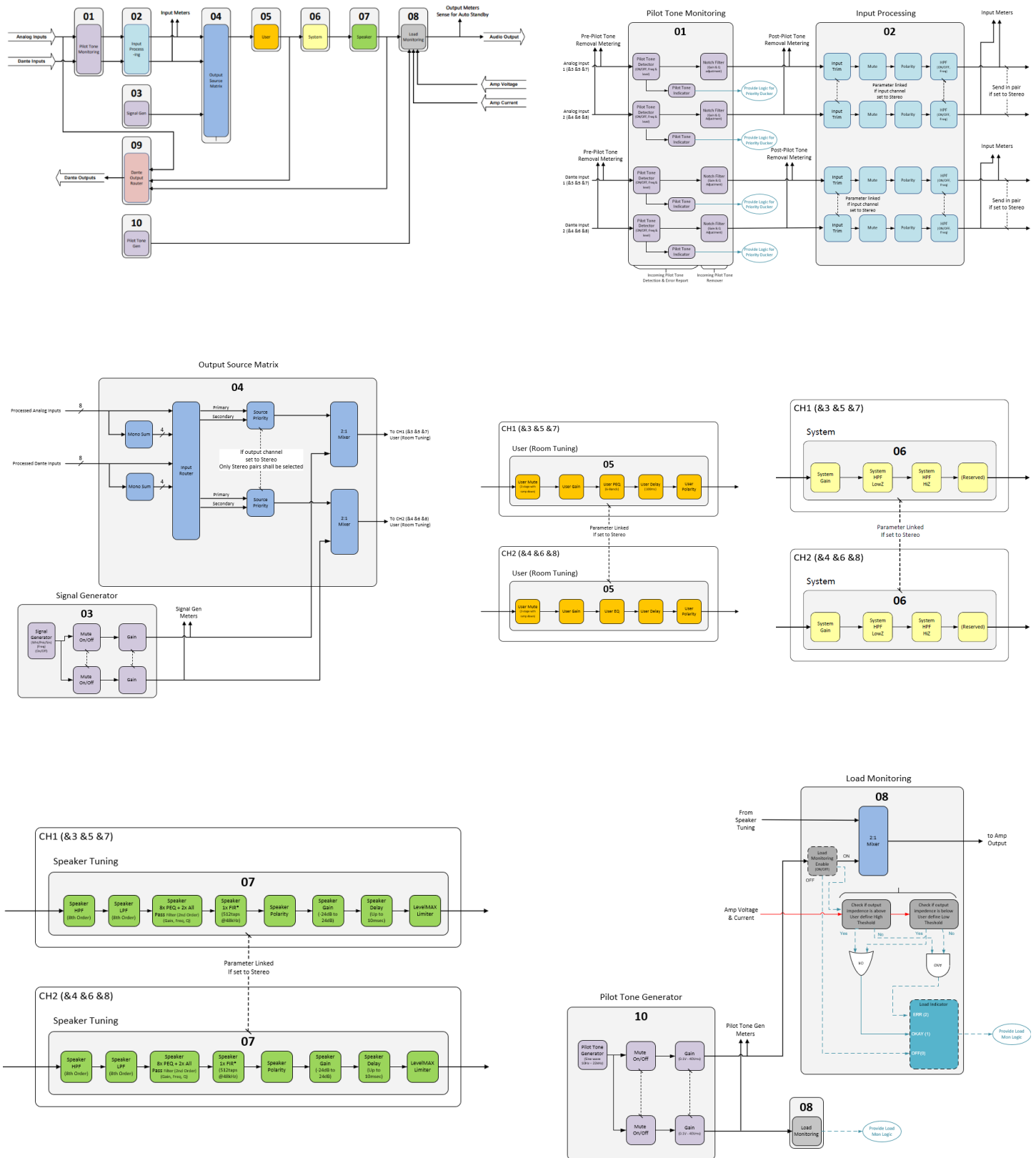

## Specification

	CTD-2125	CTD-4125	CTD-8125
Channels	2	4	8
<b>CONNECTORS</b>			
Analog Audio Input	3.5mm Phoenix Terminal Block connector		
Digital Audio Input/Output (Dante/AES67)	2x RJ45		
Speaker Output	5.08mm Phoenix Terminal Block connector		
GPI	4in, 6pin 3.5mm Phoenix Terminal Block Connector	8in, 2x 6pin 3.5mm Phoenix Terminal Block Connector	
Fault Relay Output	NO, COM, NC 3.5mm Phoenix Terminal Block Connector		
Power	Standard IEC		
<b>POWER (1kHz, 20MS BURST, ALL CHANNELS DRIVEN, 0.1% THD)</b>			
Rated Power (8Ω)	125W x 2	125W x 4	125W x 8
Rated Power (4Ω)	125W x 2	125W x 4	125W x 8
Rated Power (70V/100V)	125W x 2	125W x 4	125W x 8
<b>POWER SHARING (1kHz, 20MS BURST, SINGLE CHANNELS DRIVEN, 0.1% THD)</b>			
Rated Power (8Ω)	250W x 1	500W x 1	500W x 2
Rated Power (4Ω)	250W x 1	500W x 1	500W x 2
Rated Power (70V/100V)	250W x 1	500W x 1	500W x 2
<b>PERFORMANCE</b>			
Crosstalk (below rated power) 20 Hz to 1 kHz	<-90dB		
Common Mode Rejection (20 Hz to 1 kHz)	> 55 dB		
Damping Factor (20Hz to 100Hz)	≥100		
Digital Signal Processing	48kHz		
Frequency response @ 4/8 ohm	20 Hz - 20 kHz +/- 0.5 dB		
Intermodulation Distortion (60Hz and 7kHz AT 4:1, From -30dB To Full Rated Power)	≤0.35%		
Input Impedance	20k, balanced		
Input Sensitivity @ 8 ohm	1.12Vrms (2ch)	1.58Vrms (4 & 8ch)	
Maximum Fan Noise (Red. dB SPL @ 1M)	48dB		
Maximum Input Level	+20dBu		
Signal to Noise Ratio (below rated power 20 Hz to 20 kHz, A-Weighted)	104dB Analog, 113dB Dante		
THD+N at 4/8Ω, 70V/100V, @1dB below rated power	≤0.1%		
Voltage Gain (8Ω, 1kHz, Vin = 100mV)	32dB		
100V Output Voltage (loaded to 250W/500W)	93Vrms		

## Specification



ELECTRICAL			
Power Supply	Universal power supply, voltage: 100-240VAC, 50/60Hz		
Power Saving	Standby Consumption GPI Standby <0.5W Auto Standby with Network Control <2W		
Wakeup Time from Sleep	<250ms		
PHYSICAL			
Dimension (DxWxH)	358 x 220 x 43 mm (14.1" x 8.6" x 1.7")	358 x 220 x 43 mm (14.1" x 8.6" x 1.7")	378 x 482 x 43 mm (14.9" x 19" x 1.7")
Net Weight	6.4 lbs (2.9 kg)	7.1 lbs (3.2 kg)	13 lbs (5.9 kg)
Shipping Weight	8.6 lbs (3.8 kg)	9.1 lbs (4.1 kg)	15.9 lbs (7.2 kg)

**Dimension Drawings**

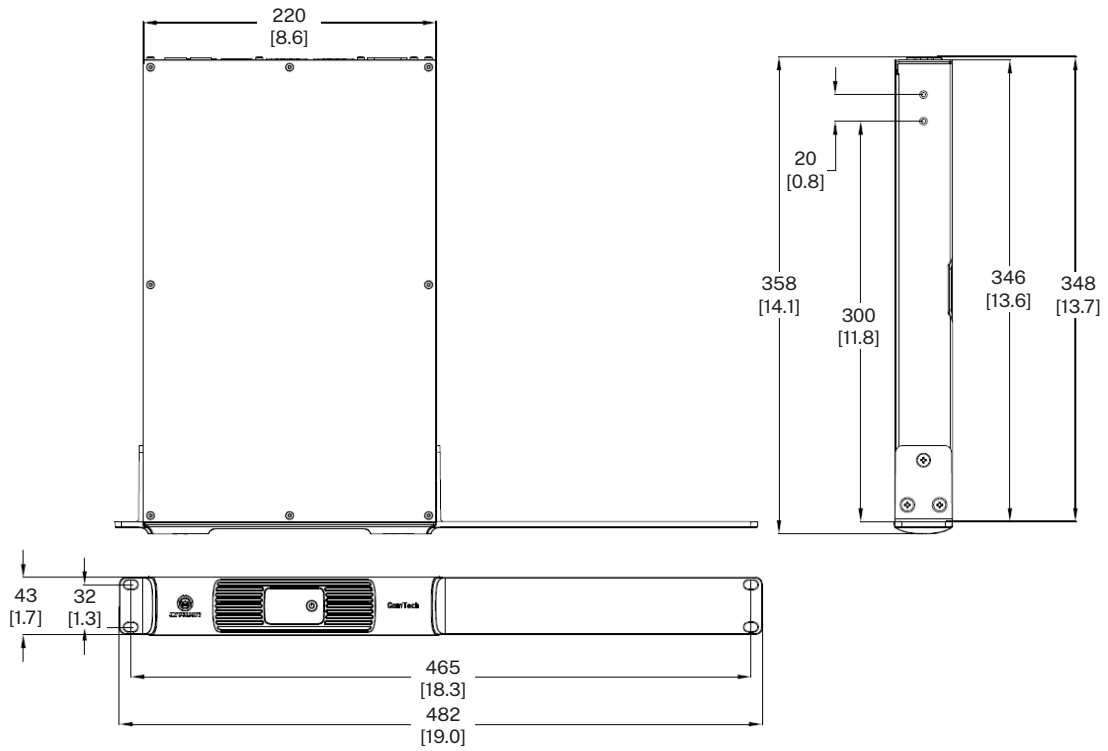

**2 & 4 Channels Version**

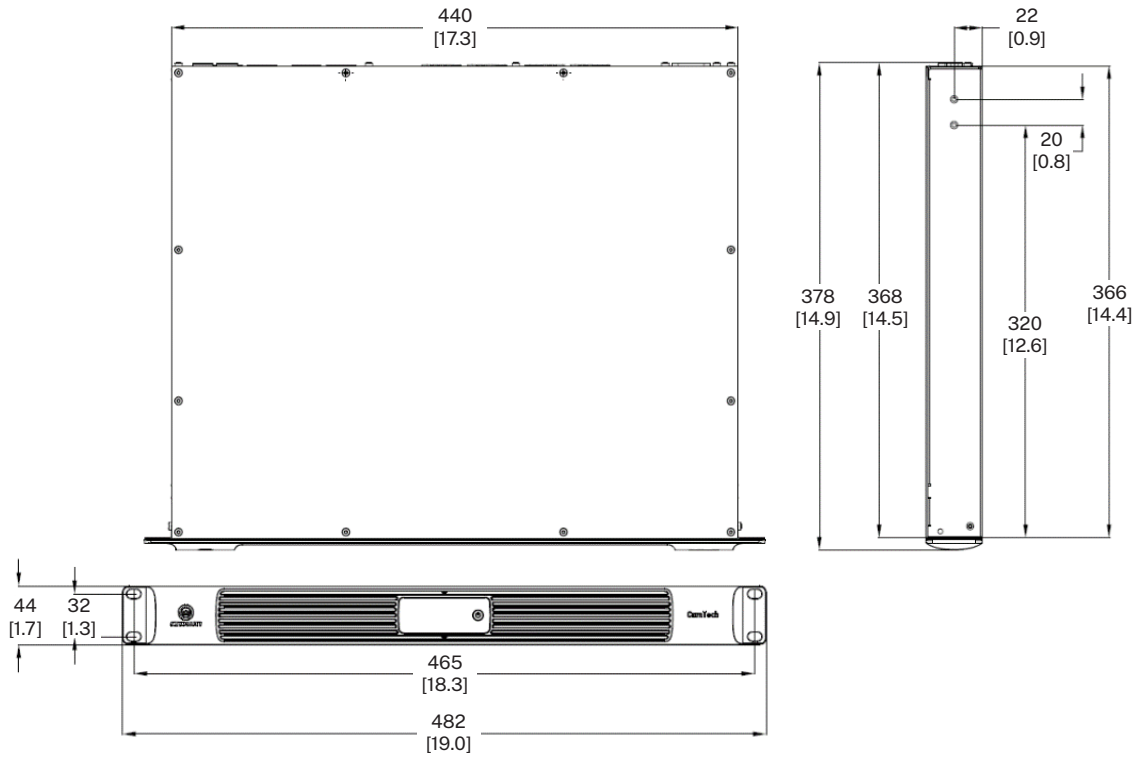

**8 Channels Version**

# Warranty (United States Only)

## SUMMARY OF WARRANTY

Crown International, 8500 Balboa Blvd. Northridge, CA 91329 U.S.A. warrants to you, the ORIGINAL PURCHASER and ANY SUBSEQUENT OWNER of each NEW Crown product, for three years from the date of purchase by the original purchaser (the "warranty period") that the new Crown product is free of defects in materials and workmanship. We further warrant the new Crown product regardless of the reason for failure, except as excluded in this Warranty.

*\* Warranty is only valid within the United States of America. For information on Warranty outside of the U.S.A, please contact your local distributor.*

## ITEMS EXCLUDED FROM THIS CROWN WARRANTY

This Crown Warranty is in effect only for failure of a new Crown product which occurred within the Warranty Period. It does not cover any product which has been damaged because of any intentional misuse, accident, negligence, or loss which is covered under any of your insurance contracts. This Crown Warranty also does not extend to the new Crown product if the serial number has been defaced, altered, or removed.

## WHAT THE WARRANTOR WILL DO

We will remedy any defect, regardless of the reason for failure (except as excluded), by repair, replacement, or refund. We may not elect refund unless you agree, or unless we are unable to provide replacement, and repair is not practical or cannot be timely made. If a refund is elected, then you must make the defective or malfunctioning product available to us free and clear of all liens or other encumbrances. The refund will be equal to the actual purchase price, not including interest, insurance, closing costs, and other finance charges less a reasonable depreciation on the product from the date of original purchase. Warranty work can only be performed at our authorized service centers or at the factory. Warranty work for some products can only be performed at our factory. We will remedy the defect and ship the product from the service center or our factory within a reasonable time after receipt of the defective product at our authorized service center or our factory. All expenses in remedying the defect, including surface shipping costs in the United States, will be borne by us. (You must bear the expense of shipping the product between any foreign country and the port of entry in the United States including the return shipment, and all taxes, duties, and other customs fees for such foreign shipments.)

## HOW TO OBTAIN WARRANTY SERVICE

You must notify us of your need for warranty service within the warranty period. All components must be shipped in a factory pack, which, if needed, may be obtained from us free of charge. Corrective action will be taken within a reasonable time of the date of receipt of the defective product by us or our authorized service center. If the repairs made by us or our authorized service center are not satisfactory, notify us or our authorized service center immediately.

## DISCLAIMER OF CONSEQUENTIAL AND INCIDENTAL DAMAGES

YOU ARE NOT ENTITLED TO RECOVER FROM US ANY INCIDENTAL DAMAGES RESULTING FROM ANY DEFECT IN THE NEW CROWN PRODUCT. THIS INCLUDES ANY DAMAGE TO ANOTHER PRODUCT OR PRODUCTS RESULTING FROM SUCH A DEFECT. SOME STATES DO NOT ALLOW THE EXCLUSION OR LIMITATIONS OF INCIDENTAL OR CONSEQUENTIAL DAMAGES, SO THE ABOVE LIMITATION OR EXCLUSION MAY NOT APPLY TO YOU.

## WARRANTY ALTERATIONS

No person has the authority to enlarge, amend, or modify this Crown Warranty. This Crown Warranty is not extended by the length of time which you are deprived of the use of the new Crown product. Repairs and replacement parts provided under the terms of this Crown Warranty shall carry only the unexpired portion of this Crown Warranty.

## DESIGN CHANGES

We reserve the right to change the design of any product from time to time without notice and with no obligation to make corresponding changes in products previously manufactured.

## LEGAL REMEDIES OF PURCHASER

THIS CROWN WARRANTY GIVES YOU SPECIFIC LEGAL RIGHTS, YOU MAY ALSO HAVE OTHER RIGHTS WHICH VARY FROM STATE TO STATE. No action to enforce this Crown Warranty shall be commenced after expiration of the warranty period.

THIS STATEMENT OF WARRANTY SUPERSEDES ANY OTHERS CONTAINED IN THIS MANUAL FOR CROWN PRODUCTS.

## Service

Crown products are quality units that rarely require servicing. Before returning your unit for servicing, please contact Crown Technical Support to verify the need for servicing.

*Warranty is only valid within the country in which the product was purchased.*

This unit has very sophisticated circuitry which should only be serviced by a fully trained technician. This is one reason why each unit bears the following label:



**CAUTION: To prevent electric shock, do not remove covers. No user serviceable parts inside. Refer servicing to a qualified technician.**

Complete the Service Return Authorization form in the back of this manual, when returning a Crown product to the factory or authorized service center. The form must be included with your product inside the box or in a packing slip envelope securely attached to the outside of the shipping carton. Do not send this form separately.

### Worldwide Service

Service may be obtained from an authorized service center (contact your local Crown/Amcron representative or our office for a list of authorized service centers). To obtain service, simply present the bill of sale as proof of purchase along with the defective unit to an authorized service center. They will handle the necessary paperwork and repair.

Remember to transport your unit in the original factory pack.

### US and Canada Service

Service may be obtained in one of two ways: from an authorized service center or from the factory. You may choose either. It is important that you have your copy of the bill of sale as your proof of purchase.

### Service at a US or Canada Service Center

This method usually saves the most time and effort. Simply present your bill of sale along with the defective unit to an authorized service center to obtain service. They will handle the necessary paperwork and repair. Remember to transport the unit in the original factory pack. A list of authorized service centers in your area can be obtained from Crown Factory Service, or online from <https://www.crownaudio.com/en/support/repairs>

### Factory Service

Crown accepts no responsibility for non-serviceable product that is sent to us for factory repair. It is the owner's responsibility to ensure that their product is serviceable prior to sending it to the factory.

SPOC (Single Point of Contact) for SERVICE/WARRANTY:

HProTechSupportUSA@harman.com Tech Support

HProWarrantyClaims@harman.com Warranty claims

<https://pro.harman.com/service> General service site, assistance from After-Sales Services 844-776-4899

For SERVICE/WARRANTY Outside the US., Please contact your local CROWN/HARMAN Representative.