



Tech Made Simple

The Crown® PRESSURE ZONE MICROPHONE® (PZM®)

THE PROBLEM

Recording engineers often must place microphones near hard reflective surfaces. Some situations where this occurs are recording drama or opera with microphones near the stage floor, recording a piano with the mics near the open lid, or recording an instrument surrounded by reflective baffles.

In these situations, sound travels from the sound source to the microphone via two paths: directly from the source to the microphone, and reflected off the surface (Figure 1, left). Note that the reflected sound travels a longer distance than the direct sound, so the reflected sound is delayed relative to the direct sound. When the direct and delayed sounds combine at the microphone diaphragm, this results in phase cancellations of various frequencies. A series of peaks and dips is created in the net frequency response. This is called a comb-filter effect. It colors the tone quality and gives an unnatural sound.

To solve this problem, we need to shorten the delay of the reflected sound so that it arrives at the mic at the same time as the direct sound.

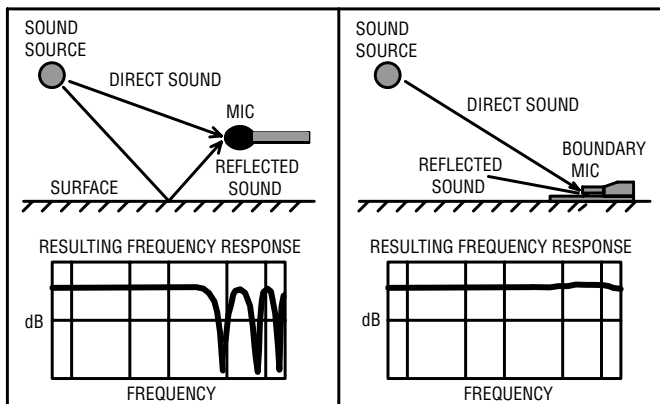

Figure 1. Conventional mic vs. a PZM

THE PZM SOLUTION

A new kind of microphone was developed to solve the problem of phase interference from sound reflections: the Pressure Zone Microphone or PZM.

In a PZM, the diaphragm can be placed as close to the surface as desired. Then the direct and reflected waves arrive at the microphone at the same time, in phase (Figure 1, right). This eliminates phase cancellations and results in a smooth frequency response. The diaphragm is mounted in the "pressure zone" just above the plate, a region where the direct and reflected waves are effectively in-phase.

This special microphone was designed to be used on surfaces such as floors, walls, tables, or even piano lids. It includes a miniature omnidirectional condenser mic capsule, which is mounted face-down next to a sound-reflecting plate. The microphone diaphragm is parallel with and very close to the reflecting surface (Figure 2).

Typical applications for PZMs are:

- grand piano (taped to the underside of the lid)
- ambience miking (on the floor or walls)
- stereo recording of orchestras, symphonic bands and small ensembles (mounted on a panel)
- drum set

The PZM was invented in 1978 by audio consultant Ed Long and recording engineer Ron Wickersham. Ken Wahrnbrock marketed the first PZM prototypes, and Crown started manufacturing PZMs in 1980.

PZM BENEFITS

- Eliminates phase cancellations, giving a clear, natural sound.
- 6 dB higher sensitivity and 6 dB better signal-to-noise ratio (improved "reach").
- Unchanging tone quality as the sound source moves.
- Lack of off-axis coloration.
- Small size, inconspicuous.
- Hemispherical polar pattern. It can be shaped by the addition of panels near the mic capsule.

TO LEARN MORE

Go to www.crownaudio.com and click on Microphones. Then select Document Library. Look under Microphone Application Guides to find the *Crown Boundary Microphone Application Guide*.

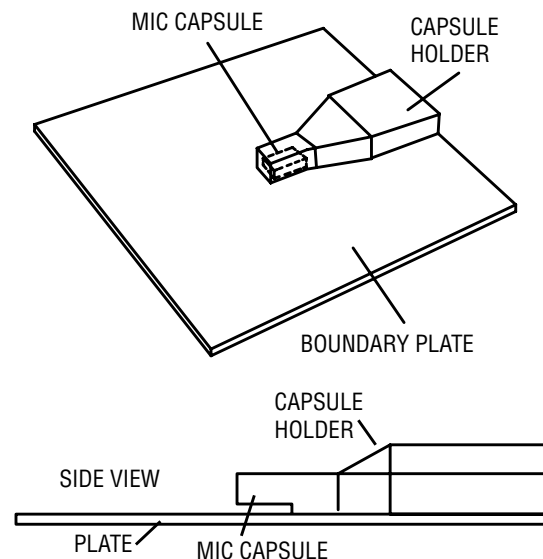

Figure 2. PZM construction

©2005 by Crown Audio, Inc.
1718 W. Mishawaka Rd, Elkhart, Indiana 46517-9439 USA Tel:
574-294-8000
136367-2 2/05
Crown and PZM are registered trademarks of Crown International