

LM-201 LM-201L

The Crown® LM-201 and LM-201L are professional-quality, supercardioid electret condenser microphone designed for use on lecterns, pulpits, or similar applications.

The LM-201 is available in two lengths LM-201 has an 16 inch (40.6 cm) arm and the LM-201L has a 24 inch (61 cm) arm. (See Figure 3a.)

The microphone is easily installed with the included mounting screws. As it is swiveled to the desired position, adjustment is far quieter than conventional gooseneck microphones. Swivel motion is limited to prevent cable damage. The LM-201 is rugged and is built to withstand daily use.

Because of its supercardioid pickup pattern, the LM-201 rejects background noise and room reverberation, improving gain-before-feedback more than a microphone with a cardioid pattern.

The LM-201 has a smooth, wide-range frequency response for natural reproduction of the voice. Low frequencies are filtered out to reduce pickup of lectern thumps, room rumble, etc.

The included wire-screen grille has a two-stage pop filter to reduce pickup of explosive breath sounds. An external foam windscreen is supplied for extra pop rejection or for outdoor use. The base and mic capsule are shock-mounted to attenuate handling noise and lectern thumps.

The microphone output is balanced, low impedance, which allows long cable runs without hum pickup or high-frequency loss.

Two finishes are available: black (model LM-201 and LM-201PL) or brown (model LM-201B).

Operating Instructions

The LM-201 comes in two parts: a microphone/swivel mount and an electronics module.

Mounting:

1. Using the swivel mount as a template, mark and drill three 1/8-inch-diameter (3.175-mm) holes for the mounting screws (supplied).

NOTE: Your pulpit might already have mounting holes that fit the LM-201. If these holes are oriented opposite to those in the LM-201 base, simply remove the Phillips pan-head screw from the side of the base and align the holes in the base with those in the pulpit. Then, rotate the boom arm 180°, reinsert the pan-head screw into the hole in the side of the base and mount the base to the pulpit.

SUPERCARDIOID CONDENSER LECTERN MICROPHONE



Specifications

Type: Unidirectional condenser.

Element: Electret condenser.

Frequency response (typical): 100 Hz to 15,000 Hz. See Fig. 1.

Polar pattern: Supercardioid. See Fig. 2.

Impedance: 150 ohms nominal (120 ohms actual), balanced. Recommended minimum load impedance 1000 ohms.

Open-circuit sensitivity: 6.0 mV/Pa* (-44.5 dBV/Pa).

Power sensitivity: -42 dB re 1 mW/Pa*.

Equivalent noise level: 24 dB SPL typical (0 dB = .0002 dyne/cm²), A-weighted.

S/N ratio: 70 dB at 94 dB SPL.

Maximum SPL: 120 dB SPL for 3% THD.

Polarity: Positive pressure on the diaphragm produces a positive voltage on XLRM pin 2 with respect to pin 3.

Operating voltage:

Option 1: Phantom power, 12 to 48 volts DC, positive voltage on output pins 2 and 3 with respect to pin 1.

Option 2: 12-24 DC power supplied by a separate AC/DC adapter such as Crown PS-24. You select this option by moving jumpers inside the electronics module (instructions inside cover).

Current drain: 5.8 mA.

Materials: Polycarbonate swivel mount and ball, steel tube and grille, steel electronics module.

Finish: Black (LM-201) or brown (LM-201B).

Cables: Grey, permanently attached, 2-conductor shielded cable, terminated with spade lugs for connection to electronics module. Six-and-one-half feet (2 meters) long from swivel mount to spade lugs. Black, permanently attached, 2-conductor shielded cable, 18 inches (0.5 meters) long, with 3-pin male XLR audio connector.

Weight (microphone and cable only): LM-201: 10.2 ounces (288.3 grams). LM-201L: 12.3 ounces (348.7 grams).

Weight (microphone, cable, and electronics module): LM-201: 18.2 ounces (515 grams). LM-201L: 20.3 ounces (575.4 grams).

Dimensions: See Figs. 3a, 3b and 3c.

Included accessories: Foam windscreen, Crown part no WS-8.

Optional accessories: PH-1A phantom power supply (1 ch., battery or AC adapter powered), PH-4B phantom power supply (4 ch., AC powered).

*1 Pascal = 10 dynes/cm² = 10 microbars = 94 dB SPL.

Fig. 1

Frequency Response

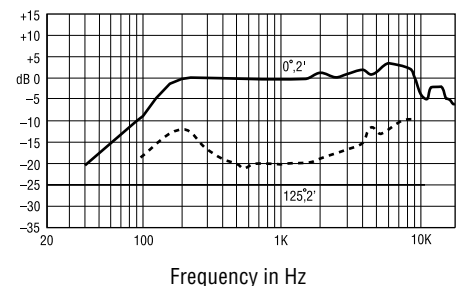

Fig. 2

Horizontal-Plane Polar Response

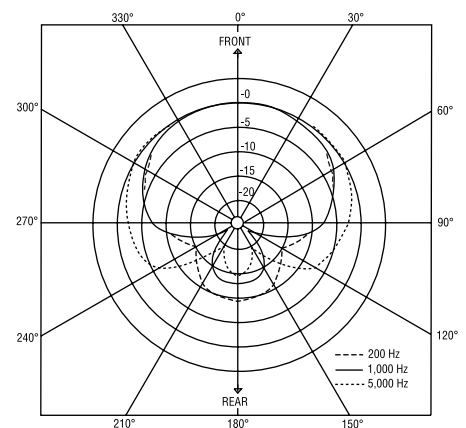
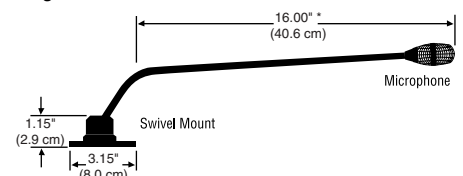

Fig. 3a



* The LM-201L has a 24 inch (61 cm) arm.

LM-201 LM-201L

Fig. 3b

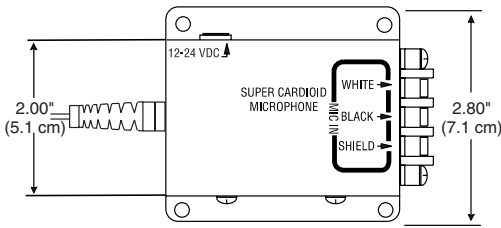

2. Drill a 1/2-inch-diameter (12.7-mm) hole in the lectern top in the center of the three 1/8-inch-diameter (3.175-mm) holes. The microphone cable will run through this hole.

Alternatively, you can run the cable along the top of the lectern and down the side, so that no cable hole is needed.

3. Using the supplied mounting screws and washers, screw the swivel mount to the lectern top. Tighten the mounting screws securely. Do not overtighten. Some slight wobbling of the base is normal when the microphone is moved.

4. For unlimited microphone rotation, remove the set screw in the base of the microphone.

Caution: If the boom arm is rotated fully around, it may twist and damage the microphone cable.

5. Using woodscrews, mount the base plate of the electronics module inside the lectern or wherever desired. You can remove the module cover by undoing the screws on the side of the module.

Powering: The LM-201 is factory set for use with 12-48 volt phantom power. To change to 12-24 volt DC power, see instructions inside electronics module cover.

Fig. 3c

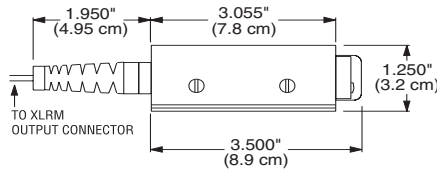

Connections: Connect the LM-201 cable spade lugs to the electronics module as shown in Figure 3b. Plug mixer cable into the 3-pin XLRM output connector (see Figure 3c).

Warning: Do not lubricate the microphone swivel mount, as it may lose its friction and not stay in place. Use only mild soap and water to clean the microphone.

Tension Adjustment: If the swivel becomes loose, remove the swivel mount from the lectern and look under the mount. You'll see a ring with two holes 180 degrees apart. Place the tips of a needleless pliers in these holes, and rotate the ring clockwise until the swivel is sufficiently tight. Remount the unit.

Architects' and Engineers' Specifications

The microphone shall be the Crown model LM-201 or equivalent. The microphone shall be a supercardioid electret-condenser type with shock-mounted capsule, a built-in shock-mounted swivel mount and pop-filter grille. Permanently attached to the microphone shall be a 6.5-ft (2-m), two-conductor shielded cable that connects to a supplied electronics module. The output of the electronics module shall have an 18-in. (0.5-m) microphone cable terminated with an XLRM audio connector.

The microphone shall be powered from 12 to 48 volts phantom powering or 12-24 volts DC. Frequency response shall be uniform from 100 Hz to 15,000 Hz. Open-circuit sensitivity shall be 6.0 mV/Pa. Impedance shall be 150 ohms balanced. Maximum SPL capability shall be 120 dB SPL at 3% THD. Equivalent noise shall be 24 dBA typical (0 dB = 0.002 dyne/cm²).

The LM-201 and LM201PL shall have a black finish; the LM-201B shall have a brown finish.

The LM-201 has an 16 inch (40.6 cm) arm and the LM-201L has a 24 inch (61 cm) arm.

The Crown Model LM-201, LM-201L or LM-201PL microphone is specified.

Microphone Warranty

Crown professional microphones are guaranteed against malfunction for a period of three years from date of original purchase. See enclosed warranty sheet for additional information.

Service

If the unit fails to work, replace or repair any additional mic cables, or check the power supply. If service is required, return both the microphone and its interface in their original packaging to **Crown Factory Service, 1718 West Mishawaka Road, Elkhart, IN 46517**. For further assistance or technical support call **800-342-6939**.

At the factory, the electronics module is matched to your particular microphone's frequency response. If you determine that just the microphone or the module needs service, send both anyway. Then we can match your electronics to your microphone. The serial number is on both pieces.

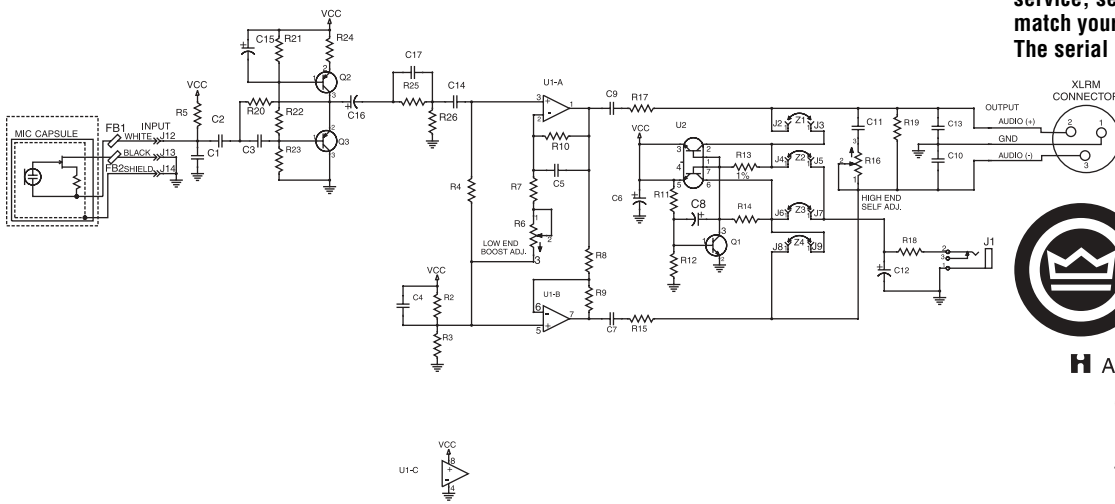

LM-201/LM-201L Schematic



H A Harman International Company

Crown International
P.O. Box 1000
Elkhart, IN 46515-1000
TEL: 574-294-8000
FAX: 574-294-8FAX
www.crownaudio.com

©2002 Crown Audio, Inc.
Specifications subject to change without prior notice.
Crown® is a registered trademark of Crown International.
8/02