

CM-200A

CARDIOID CONDENSER MICROPHONE

The Crown® CM-200A is a cardioid condenser microphone for professional vocal and instrumental use. It offers studio quality sound, yet is rugged enough to withstand hard professional use in the field. Its outstanding performance is complemented with handsome styling and a comfortable balance.

The sound of the CM-200A is smooth and non-harsh – yet very articulate – with a wider frequency range than standard vocal microphones. When used up-close, its proximity effect boosts the low-frequency response for a warm, robust sound. An upper-midrange “presence peak” adds intelligibility.

The cardioid polar pattern increases gain-before-feedback, rejects unwanted background noise, and discriminates against sounds approaching the rear of the microphone.

A built-in multi-stage pop filter effectively suppresses explosive breath sounds. Handling noise is extremely low. The unit can withstand repeated drops and abuse, as well as extremely loud sound pressure levels without distortion.

The output of the CM-200A is balanced, low impedance, which allows long cable runs without hum pickup or high-frequency loss. The unit can be phantom powered from the console or other remote power supply.

Included with the CM-200A is a convenient carrying pouch, an adjustable microphone stand adapter for mounting the unit to any microphone stand, and a foam windscreen to further reduce breath popping and wind noise.

Operating Instructions

Using a 2-conductor shielded microphone cable (not supplied), plug the microphone into a mixer mic input with 12 to 48 volts phantom powering or use a remote phantom power supply. Crown makes a PH-4B phantom power supply (4 channels, AC powered) and a PH-1A phantom power supply (1 channel, battery or AC-adaptor powered). For special applications, you can make your own battery supply as suggested in Fig. 4.

For maximum gain before feedback, sing close to the microphone (lips touching the grille) and place loudspeakers forward of the rear of the microphone (upstage from the performer).

For outdoor or vocal use, you may want to place the included foam windscreen on the microphone to reduce wind noise and breath popping.



Specifications

Type: Cardioid condenser vocal-instrumental microphone.

Element: Electret condenser.

Frequency Response (typical): 80 Hz to 15,000 Hz. See Fig. 1.

Polar Pattern: Cardioid (see Fig. 2).

Impedance: 150 ohms nominal, 200 ohms actual, balanced. Recommended minimum load impedance 1000 ohms.

Open Circuit Sensitivity (48 V supply): 3.0 mV/Pa* (-53 dBV/Pa).

Power Sensitivity: -52 dBm/Pa*.

Equivalent Noise Level (self-noise): 21.5 dB SPL typical (0 dB = .0002 dyne/cm²), A-weighted.

S/N Ratio: 72.5 dB at 94 dB SPL.

Maximum SPL for 3% THD: 151 dB SPL with 48-V supply; 143 dB SPL with 12-V supply.

Polarity: Positive pressure on the diaphragm produces a positive voltage on pin 2 with respect to pin 3 of output connector.

Operating Voltage: Phantom power, 12 to 48 volts DC, positive voltage on pins 2 and 3 with respect to pin 1 of output connector.

Current Drain: 1.7 mA.

Materials: Rugged aluminum alloy housing, steel grille.

Finish: Satin black.

Cable: None supplied; use 2-conductor shielded microphone cable.

Connector: 3-pin male XLR type.

Net Weight: 7 oz. (199 g).

Dimensions: See Fig. 3 on reverse side.

Included Accessories: Carrying pouch, ASA-2 microphone stand adapter and WS-4 windscreen.

Optional Accessories: Crown PH-1A phantom power supply (1 channel, battery or AC adapter powered), and Crown PH-4B phantom power supply (4 channels, AC powered).

Fig. 1 Frequency Response

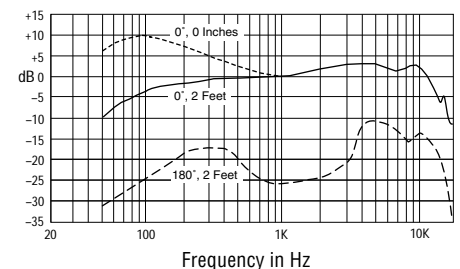
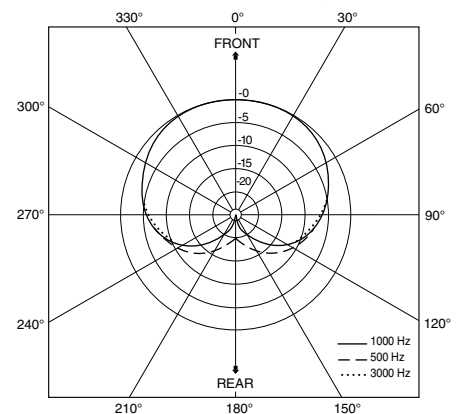

Fig. 2 Horizontal-Plane Polar Response



*1 pascal = 10 dynes/cm² = 10 microbars = 94 dB SPL.

CM-200A

Fig. 3

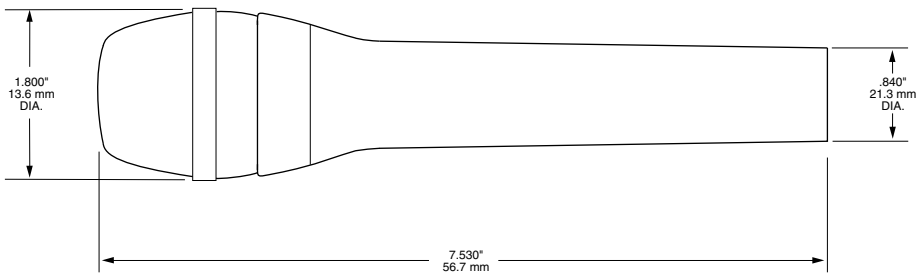
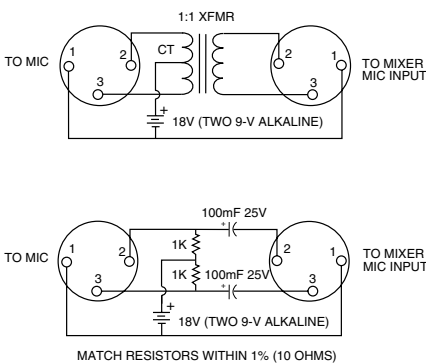

Fig. 4



Several placement examples are described in the *Crown Microphone Application Guide*, the Crown Literature Department, or on Crown's web site at www.crownaudio.com.

Architects' and Engineers' Specifications

The microphone shall be the Crown Model CM-200A. The microphone shall be a cardioid condenser type requiring 12 to 48 volts phantom powering. A smooth frequency response from 80 Hz to 15,000 Hz shall be obtained, with a uniform off-axis response.

The microphone shall have a sensitivity of 2.2 mV/Pa (-53 dBV/Pa) when operated with a 48-V phantom power supply. Maximum SPL shall be 151 dB SPL at 3% THD. Equivalent noise shall be 21.5 dBA typical (0 dB = .0002 dyne/cm²). The Crown model CM-200A microphone is specified.

Warranty

Crown professional microphone products are guaranteed against malfunction for a period of three years from date of original purchase. See enclosed warranty sheet for additional information.

Service

If the microphone does not function properly, replace or repair the mic cables and check the power supply.

If you determine the microphone product(s) is defective, return the complete product in its original packaging to: **Crown Factory Service, 1718 West Mishawaka Road, Elkhart, IN 46517**. For further assistance or technical support call **800-342-6939**.

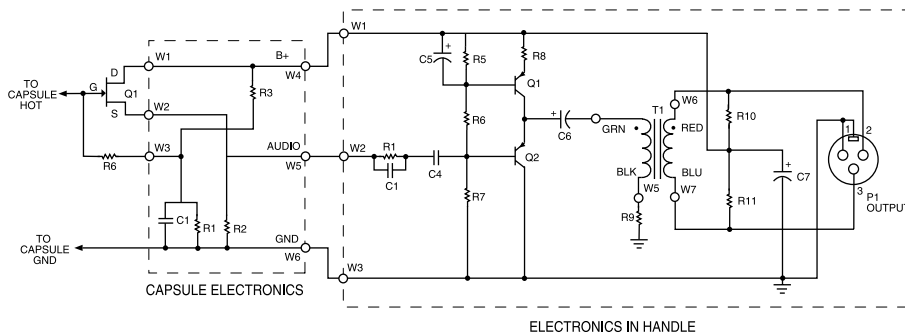

CM-200A Schematic



A Harman International Company

Crown International, Inc.
P.O. Box 1000
Elkhart, IN 46515-1000
TEL: 574-294-8000
FAX: 574-294-8FAX
www.crownaudio.com

©2003 Crown Audio, Inc.
Crown is a registered trademark of Crown International, Inc. Specifications subject to change without prior notice. Latest information available at www.crownaudio.com.