

IQ-PSI

REFERENCE MANUAL



IQ System® to Host Computer Pocket Serial Interface

© 1997 by Crown International, Inc., P.O. Box 1000, Elkhart, Indiana 46515-1000 U.S.A. Telephone: 219-294-8000. The *IQ-PSI* is produced by the Professional Audio Division of Crown International, Inc. Trademark Notice: *IQ2™* is a trademark and *Crown®*, *Amcron®*, *IQ System®* and *P.I.P.®* are registered trademarks of Crown International, Inc. Other trademarks are the property of their respective owners.



Printed on
recycled paper.



THREE YEAR FULL WARRANTY



WORLDWIDE

NORTHAMERICA

SUMMARY OF WARRANTY

The Crown Audio Division of Crown International, Inc., 1718 West Mishawaka Road, Elkhart, Indiana 46517-4095 U.S.A. warrants to you, the ORIGINAL PURCHASER and ANY SUBSEQUENT OWNER of each NEW Crown¹ product, for a period of three (3) years from the date of purchase by the original purchaser (the "warranty period") that the new Crown product is free of defects in materials and workmanship, and we further warrant the new Crown product regardless of the reason for failure, except as excluded in this Crown Warranty.

¹ Note: If your unit bears the name "Amcron," please substitute it for the name "Crown" in this warranty.

ITEMS EXCLUDED FROM THIS CROWN WARRANTY

This Crown Warranty is in effect only for failure of a new Crown product which occurred within the Warranty Period. It does not cover any product which has been damaged because of any intentional misuse, accident, negligence, or loss which is covered under any of your insurance contracts. This Crown Warranty also does not extend to the new Crown product if the serial number has been defaced, altered, or removed.

WHAT THE WARRANTOR WILL DO

We will remedy any defect, regardless of the reason for failure (except as excluded), by repair, replacement, or refund. We may not elect refund unless you agree, or unless we are unable to provide replacement, and repair is not practical or cannot be timely made. If a refund is elected, then you must make the defective or malfunctioning product available to us free and clear of all liens or other encumbrances. The refund will be equal to the actual purchase price, not including interest, insurance, closing costs, and other finance charges less a reasonable depreciation on the product from the date of original purchase. Warranty work can only be performed at our authorized service centers. We will remedy the defect and ship the product from the service center within a reasonable time after receipt of the defective product at our authorized service center.

HOW TO OBTAIN WARRANTY SERVICE

You must notify us of your need for warranty service not later than ninety (90) days after expiration of the warranty period. All components must be shipped in a factory pack. Corrective action will be taken within a reasonable time of the date of receipt of the defective product by our authorized service center. If the repairs made by our authorized service center are not satisfactory, notify our authorized service center immediately.

DISCLAIMER OF CONSEQUENTIAL AND INCIDENTAL DAMAGES

YOU ARE NOT ENTITLED TO RECOVER FROM US ANY INCIDENTAL DAMAGES RESULTING FROM ANY DEFECT IN THE NEW CROWN PRODUCT. THIS INCLUDES ANY DAMAGE TO ANOTHER PRODUCT OR PRODUCTS RESULTING FROM SUCH A DEFECT.

WARRANTY ALTERATIONS

No person has the authority to enlarge, amend, or modify this Crown Warranty. This Crown Warranty is not extended by the length of time which you are deprived of the use of the new Crown product. Repairs and replacement parts provided under the terms of this Crown Warranty shall carry only the unexpired portion of this Crown Warranty.

DESIGN CHANGES

We reserve the right to change the design of any product from time to time without notice and with no obligation to make corresponding changes in products previously manufactured.

LEGAL REMEDIES OF PURCHASER

No action to enforce this Crown Warranty shall be commenced later than ninety (90) days after expiration of the warranty period.

THIS STATEMENT OF WARRANTY SUPERSEDES ANY OTHERS CONTAINED IN THIS MANUAL FOR CROWN PRODUCTS.

Telephone: 219-294-8200. Facsimile: 219-294-8301 9/90

SUMMARY OF WARRANTY

The Crown Audio Division of Crown International, Inc., 1718 West Mishawaka Road, Elkhart, Indiana 46517-4095 U.S.A. warrants to you, the ORIGINAL PURCHASER and ANY SUBSEQUENT OWNER of each NEW Crown product, for a period of three (3) years from the date of purchase by the original purchaser (the "warranty period") that the new Crown product is free of defects in materials and workmanship. We further warrant the new Crown product regardless of the reason for failure, except as excluded in this Warranty.

ITEMS EXCLUDED FROM THIS CROWN WARRANTY

This Crown Warranty is in effect only for failure of a new Crown product which occurred within the Warranty Period. It does not cover any product which has been damaged because of any intentional misuse, accident, negligence, or loss which is covered under any of your insurance contracts. This Crown Warranty also does not extend to the new Crown product if the serial number has been defaced, altered, or removed.

WHAT THE WARRANTOR WILL DO

We will remedy any defect, regardless of the reason for failure (except as excluded), by repair, replacement, or refund. We may not elect refund unless you agree, or unless we are unable to provide replacement, and repair is not practical or cannot be timely made. If a refund is elected, then you must make the defective or malfunctioning product available to us free and clear of all liens or other encumbrances. The refund will be equal to the actual purchase price, not including interest, insurance, closing costs, and other finance charges less a reasonable depreciation on the product from the date of original purchase. Warranty work can only be performed at our authorized service centers or at the factory. We will remedy the defect and ship the product from the service center or our factory within a reasonable time after receipt of the defective product at our authorized service center or our factory. All expenses in remedying the defect, including surface shipping costs in the United States, will be borne by us. (You must bear the expense of shipping the product between any foreign country and the port of entry in the United States and all taxes, duties, and other customs fees for such foreign shipments.)

HOW TO OBTAIN WARRANTY SERVICE

You must notify us of your need for warranty service not later than ninety (90) days after expiration of the warranty period. All components must be shipped in a factory pack, which, if needed, may be obtained from us free of charge. Corrective action will be taken within a reasonable time of the date of receipt of the defective product by us or our authorized service center. If the repairs made by us or our authorized service center are not satisfactory, notify us or our authorized service center immediately.

DISCLAIMER OF CONSEQUENTIAL AND INCIDENTAL DAMAGES
YOU ARE NOT ENTITLED TO RECOVER FROM US ANY INCIDENTAL DAMAGES RESULTING FROM ANY DEFECT IN THE NEW CROWN PRODUCT. THIS INCLUDES ANY DAMAGE TO ANOTHER PRODUCT OR PRODUCTS RESULTING FROM SUCH A DEFECT. **SOME STATES DO NOT ALLOW THE EXCLUSION OR LIMITATIONS OF INCIDENTAL OR CONSEQUENTIAL DAMAGES, SO THE ABOVE LIMITATION OR EXCLUSION MAY NOT APPLY TO YOU.**

WARRANTY ALTERATIONS

No person has the authority to enlarge, amend, or modify this Crown Warranty. This Crown Warranty is not extended by the length of time which you are deprived of the use of the new Crown product. Repairs and replacement parts provided under the terms of this Crown Warranty shall carry only the unexpired portion of this Crown Warranty.

DESIGN CHANGES

We reserve the right to change the design of any product from time to time without notice and with no obligation to make corresponding changes in products previously manufactured.

LEGAL REMEDIES OF PURCHASER

THIS CROWN WARRANTY GIVES YOU SPECIFIC LEGAL RIGHTS, YOU MAY ALSO HAVE OTHER RIGHTS WHICH VARY FROM STATE TO STATE. No action to enforce this Crown Warranty shall be commenced later than ninety (90) days after expiration of the warranty period.

THIS STATEMENT OF WARRANTY SUPERSEDES ANY OTHERS CONTAINED IN THIS MANUAL FOR CROWN PRODUCTS.

Telephone: 219-294-8200. Facsimile: 219-294-8301 9/90

The information furnished in this manual does not include all of the details of design, production, or variations of the equipment. Nor does it cover every possible situation which may arise during installation, operation or maintenance. If you need special assistance beyond the scope of this manual, please contact our Technical Support Group.

Crown Audio Division Technical Support Group

Plant 2 SW, 1718 W. Mishawaka Rd., Elkhart, Indiana 46517 U.S.A.

Phone: **800-342-6939** (North America, Puerto Rico and Virgin Islands) or 219-294-8200

Fax: 219-294-8301 Fax Back (North America only): 800-294-4094 or 219-293-9200

Fax Back (International): 219-294-8100 Internet: <http://www.crownintl.com>

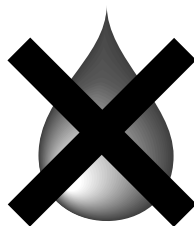

WARNING

**TO REDUCE THE RISK OF ELECTRIC
SHOCK, DO NOT EXPOSE THIS
EQUIPMENT TO RAIN OR MOISTURE!**

CONTENTS

1 Welcome	5
1.1 Unpacking	5
2 Facilities	6
3 Installation	8
3.1 Setting the IQ Address	8
3.2 Connecting to the Crown Bus	8
3.3 Connecting to a Host Computer	10
3.1.1 Setting the Baud Rate	10
3.4 Connecting Auxiliary Devices	11
3.4.1 AUX Output	11
3.4.2 AUX Input	11
4 Technical Information	12
5 Specifications	13
6 IQ Address Tables	14
7 Service	16
7.1 Worldwide Service	16
7.2 North American Service	16
7.2.1 Service at a N. American Service Center	16
7.2.2 Factory Service	16

ILLUSTRATIONS

1.1 The <i>IQ-PSI</i>	5
2.1 Front and Bottom Views of an <i>IQ-PSI</i>	6
2.2 Rear View of an <i>IQ-PSI</i>	7
3.1 An <i>IQ System</i> with an <i>IQ-PSI</i>	8
3.2 IQ Address Switch (SW3) Values	8
3.3 A Screw-Terminal Plug	9
3.4 <i>IQ-PSI</i> Output Connection to an IQ Mixer Input	9
3.5 IQ <i>P.I.P.</i> Output Connection to the <i>IQ-PSI</i> Input	9
3.6 <i>IQ-PSI</i> Output Connection to an IQ <i>P.I.P.</i> Input	9
3.7 Crown Bus Wiring "Loops" from Output to Input	10
3.8 RS232 Cable Wiring	10
3.9 Baud Rate Settings	10
3.10 The Internal AUX Port Circuit	11
3.11 A Sample AUX Output Circuit	11
4.1 <i>IQ-PSI</i> Circuit Block Diagram	12
6.1 IQ Address Switch (SW3) Settings from 0 to 125	14
6.2 IQ Address Switch (SW3) Settings from 126 to 250	15



Fig. 1.1 The IQ-PSI

1 Welcome

The IQ Pocket Serial Interface (*IQ-PSI*) is designed to serve as a portable IQ interface, connecting a selected Crown Bus loop to a host computer in an *IQ System*. A member of the *IQ2™* family, the *IQ-PSI* supports all *IQ2* and legacy protocol components when operating as a system interface. In addition, the *IQ-PSI* features a standard IQ AUX port, and can function as an IQ component with its own IQ address.

The *IQ-PSI* automatically senses whether a computer is connected to it by monitoring the RTS (Request To Send) pin of its RS232 serial port. The *IQ-PSI* will operate in “interface mode” when a host computer is detected. In this mode the *IQ-PSI* can be directed by the host computer to select any IQ component on the same Crown Bus loop and send commands or retrieve data. Input messages received on the Crown Bus are transferred out the RS232 port to the host computer.

The *IQ-PSI* will function in “component mode” when a host computer is not detected. In this mode the AUX port will still be available for use, but the RS232 serial port will be inactive. In addition, the unit’s Crown Bus input and output will be closed to allow the normal flow of communication around the Crown Bus loop. Commands received at the unit’s Crown Bus input will be analyzed and executed if they are addressed to the *IQ-PSI*.

The AUX port of the *IQ-PSI* enables it to be connected to a non-IQ component. For example, the AUX port can be connected to a relay to turn on and off a remote device. Or the AUX port can send and receive simple logic signals. Whether the *IQ-PSI* is being used as an interface or as a component, the AUX port will continue to function.

The *IQ-PSI* requires a single 9-volt battery or an external AC source (an AC power adapter is included with domestic units only). Battery life is approximately one hour (alkaline cell).

This manual will help you successfully install and use this new interface. We strongly recommend you read all the instructions, warnings and cautions. Also, for your protection, please send in the warranty registration card today. And save your bill of sale—it is your **official proof of purchase**.

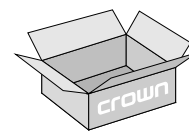

1.1 Unpacking

Please unpack and inspect the interface for any damage that may have occurred during transit. If damage is found, notify the transportation company immediately. Only you, the consignee, may initiate a claim for shipping damage. Crown will be happy to cooperate fully as needed. Save the shipping carton as evidence of damage for the shipper’s inspection.

Even if the unit arrived in perfect condition, as most do, save all packing materials so you will have them if you ever need to transport the unit. **NEVER SHIP THE UNIT WITHOUT THE FACTORY PACK.**

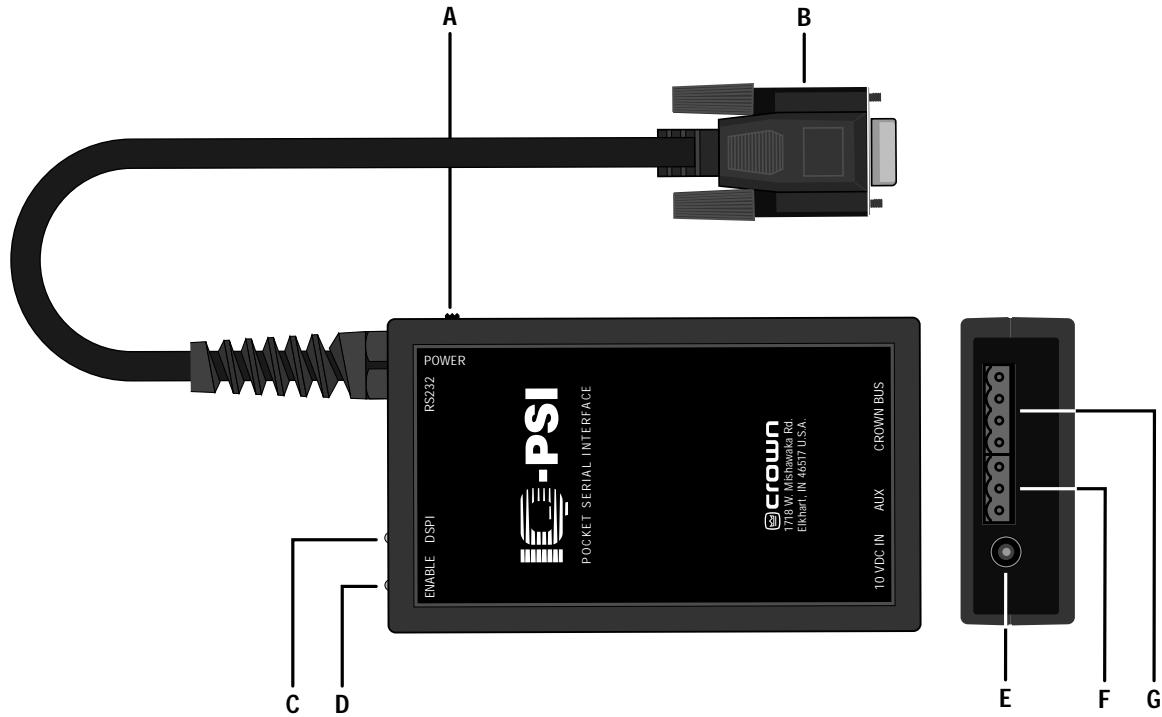

Fig. 2.1 Front and Bottom Views of an IQ-PSI

2 Facilities

A. Power Switch

This two-position sliding switch turns the unit on and off. Slide the switch toward the serial cable to turn it on. When first turned on, the green Enable indicator (D) will glow brightly and the yellow DSPI (C) will “wink” twice to show that adequate voltage is available.

B. RS232 Computer Connector & Cable

A female 9-pin “D-shell” connector and 16-inch (41-cm) cable is provided for serial connection to a host computer. The RS232 communication standard is supported. *Note: A 9-pin to 25-pin adapter will be required if the serial port of the host computer has only a 25-pin connector.* The IQ-PSI is configured so that if an active computer is plugged into the RS232, the PSI detects that the RTS is high and functions automatically as an interface; with no computer detected, it functions as an IQ component.

C. DSPI

This yellow DSPI (Data Signal Presence Indicator) flashes when the IQ-PSI sends or receives a valid IQ command. It can also be forced to stay on as an aid to

rapid troubleshooting of Crown Bus wiring. In addition, when the IQ-PSI is switched on, the DSPI will “wink” twice to show that adequate voltage is available. The absence of adequate voltage could indicate a low battery, defective AC power adapter or an AC mains low-voltage condition commonly referred to as a “brownout.”

D. Enable Indicator

This green LED lights whenever the power switch (A) of the unit is turned on and power is available.

E. External 10 VDC Power Connector

Connect the external AC power adapter (included with domestic units only) to this male coaxial DC power connector. It requires a plug with an outside diameter (O.D.) of 5.5 mm and inside diameter (I.D.) of 2.1 mm. The external power adapter should provide from 8.5 to 15 VDC at 300 mA. *Note: The center conductor of the plug should carry the positive voltage.* No battery is required when an external AC source is used. If desired, international customers should provide their own external AC power adapter which is appropriate for the AC input

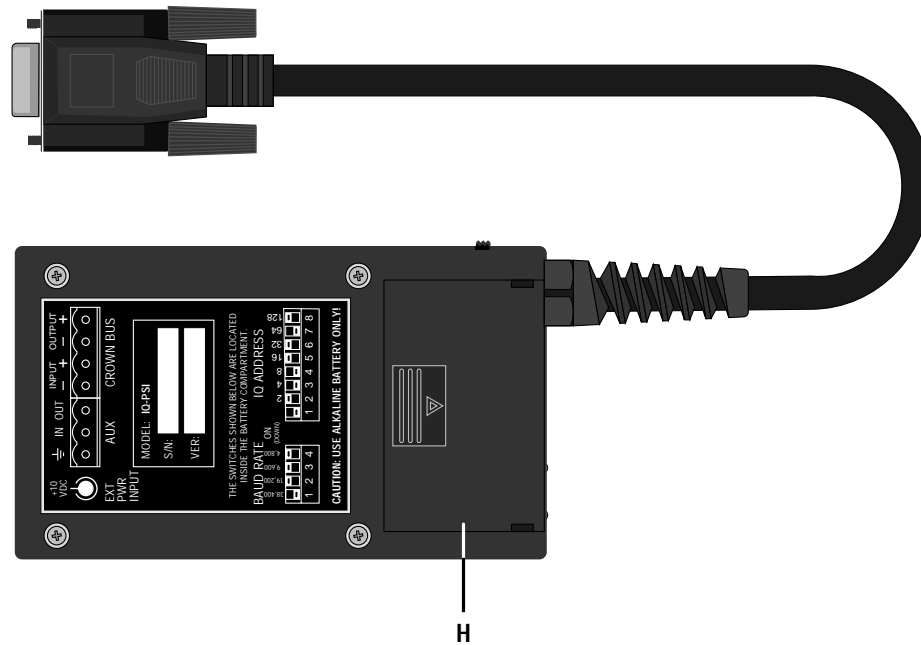

Fig. 2.2 Rear View of an IQ-PSI

voltage and receptacle connectors common to their locale. **Caution: Users of domestic units should use only the AC power adapter supplied with the unit.**

F. AUX Connector

A 3-pin male “Euro-style” connector is provided to control or send/receive signals from auxiliary equipment. When the AUX output is turned on, +10 VDC (+9 VDC if the unit is being run on battery power) is provided across the ground and output pins. A nominal current of 10 mA is available. The AUX connector also includes a high-impedance input that can sense logic signals across the ground and input pins. A mating 3-pin “Euro-style” screw-terminal plug is also provided.

G. Crown Bus Connector

A 4-pin male “Euro-style” connector is provided for connection to a single Crown Bus loop. Two pins are used for output and two pins are used for input. See Section 3.2 for more information. A mating 4-pin “Euro-style” screw-terminal plug is also provided.

H. Battery Access Panel

Remove this access panel to replace the battery or change the settings of the baud rate switch or IQ address switch. To remove the access panel, slide it toward the serial cable. **Caution: Use only alkaline batteries.**

I. Baud Rate Switch (Not Shown)

A 4-segment DIP switch (SW4), located inside the battery compartment, is used to set the baud rate. Available baud rates range from 4,800 to 38,400 baud. See Section 3.3.1 for more information.

J. IQ Address Switch (Not Shown)

An 8-segment DIP switch (SW3), located inside the battery compartment, is used to set the IQ address so multiple units can be connected to the same Crown Bus loop. Each IQ-PSI must have a unique IQ address. Section 6 lists the DIP switch settings and their corresponding IQ addresses.

3 Installation

The installation of an *IQ-PSI* can be divided into four parts: setting the IQ address, connecting to a Crown Bus loop, connecting to a host computer and connecting auxiliary devices.

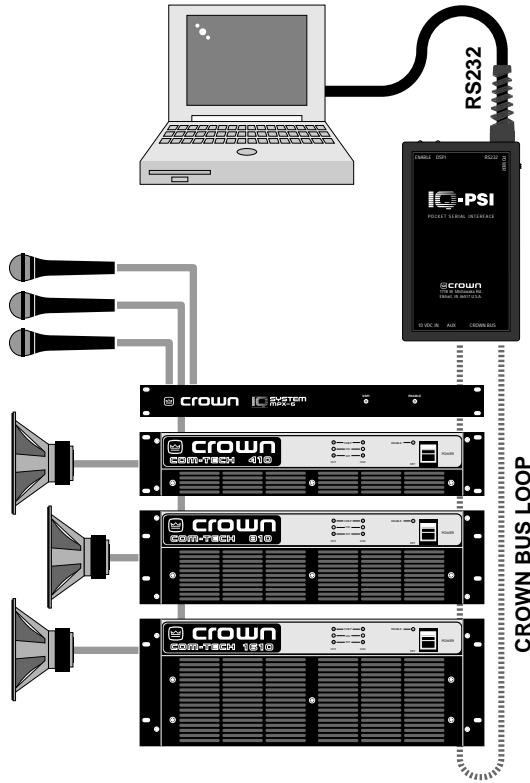

Fig. 3.1 An IQ System with an IQ-PSI

3.1 Setting the IQ Address

Since more than one *IQ-PSI* can be connected to the same Crown Bus loop, it is necessary to give each unit a unique IQ address. The IQ address is set with an 8-segment DIP switch (SW3) located inside the battery compartment.

Each segment of the DIP switch is, itself, a tiny switch and has a numerical value which doubles as the segment number increases. For example, segment 1 has a value of 1; segment 2 has a value of 2; segment 3 has a value of 4; segment 4 has a value of 8; and so on.

The address is determined by adding the values of all "ON" segments. In the example in Figure 3.2, segments 1, 3, 4 and 7 are on. Simply add the values to find the address: $1+4+8+64=77$.

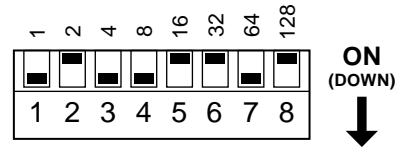

Fig. 3.2 IQ Address Switch (SW3) Values

A valid IQ address is any number from 1 to 250. Do not use a value higher than 250 since they are reserved for special use. Also, an address of "0" (zero) should not be used. A convenient series of IQ address tables are included in Section 6 at the end of this manual.

3.2 Connecting to the Crown Bus

The Crown Bus is a serial communication loop designed to transmit IQ commands and data. As a communication standard it is independent of the wiring system used. This flexibility is a great strength, enabling a Crown Bus loop to be wired with either fiber optic cabling or with inexpensive twisted-pair wire, whichever the installation requires. A single *IQ System* can have more than one Crown Bus loop. To function properly, a Crown Bus loop must be unbroken.

The Crown Bus is implemented in the *IQ-PSI* as a 20 milliamp current loop operating at 38.4 K baud, so that it can function with inexpensive twisted-pair wiring. If fiber optic wiring is required, contact Crown's Technical Support Group at 1-800-342-6939 for information on adding the appropriate transceivers.

Here are some guidelines for twisted-pair wiring:

- **When interference is a problem, use shielded twisted-pair wire** at least 26 AWG in size. The wire should be of good quality and should have low capacitance—30 pF/foot or less is good. The shield serves two purposes: First, it helps prevent the IQ data signal from transmitting to nearby audio wiring. Second, it helps prevent outside RF from interfering with the data signal. However, in most cases interference is not a problem and, since unshielded wire has lower capacitance, it is a better choice.
- **Minimize the total capacitance of a Crown Bus loop.** The total capacitance should be less than 30 nF. Allow approximately 60 pF for each IQ component in a loop. This accounts for a slight signal degradation which occurs as data signals pass through a component.
- **Add an IQ Repeater** for very long loops—greater than 1,000 feet (305 m)—or when required by high-capacitance wire. Although we recommend adding

a repeater for loops longer than 1,000 feet, it is often possible to go 2,000 feet (610 m) or more. The most significant characteristic of the wire is its capacitance. Lower capacitance allows longer loops. Unshielded wire usually has less capacitance.

- **Never use the ground wire in a mic snake line.** It may sometimes be convenient to run Crown Bus data signals to and from stage monitor amplifiers along unused wire pairs in a mic snake. Do not use the ground wire which is normally connected to pin 1 on an XLR connector, or data noise will be added to the audio lines. Use only the signal lines which normally connect to pins 2 and 3 of the XLRs. *Note: Because typical mic cables have high capacitance, the maximum possible Crown Bus loop distance will be less.*

Outside RF interference is seldom a problem for a Crown Bus loop—especially if shielded twisted-pair wire is used. However, there are extreme situations when fiber optic wiring is recommended. For example, locating a Crown Bus loop next to an AM radio transmission line may require fiber optic cabling. An extremely long Crown Bus loop distance (greater than 10 miles) may also require fiber optic cabling.

There are two different types of connectors used for Crown Bus wiring. These include DIN connectors and “Euro-style” screw terminal plugs. The *IQ-PSI* uses a 4-pin male “Euro-style” connector that accepts a complementary screw-terminal plug like the one shown in Figure 3.3. Most IQ mixers use these same plugs for Crown Bus connection.

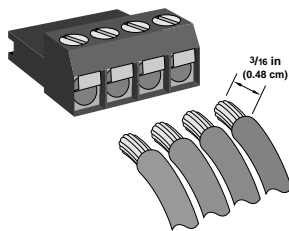

Fig. 3.3 A Screw-Terminal Plug

Figure 3.4 shows how the output of the *IQ-PSI* is wired to an IQ component with a similar connector.

Wiring the output of a similar IQ component back to the input of the *IQ-PSI* is simply the reverse. *Note: Because the IQ-PSI does not have a ground connection, the shield (if one is used) should be carried through to the input of the next IQ component with a ground*

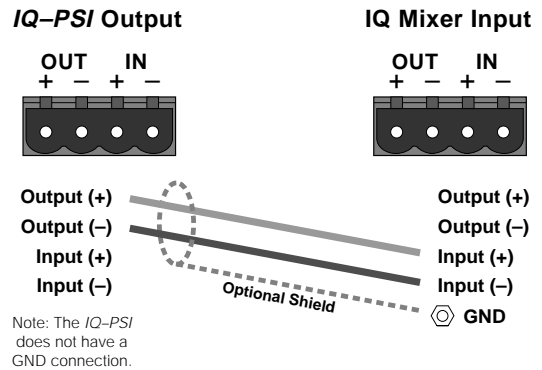

Fig. 3.4 *IQ-PSI* Output Connection to an IQ Mixer Input

connection.

The next two figures show how to wire components with different connectors. Figure 3.5 shows how to connect a

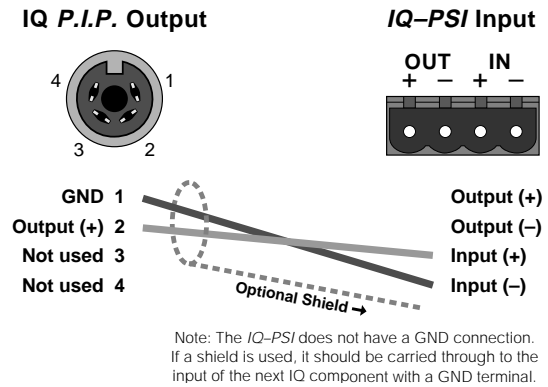

Fig. 3.5 *IQ P.I.P.* Output Connection to the *IQ-PSI* Input

4-pin DIN output connector from an *IQ P.I.P.* to the input portion of the *IQ-PSI*.

Figure 3.6 shows how to connect the output portion of

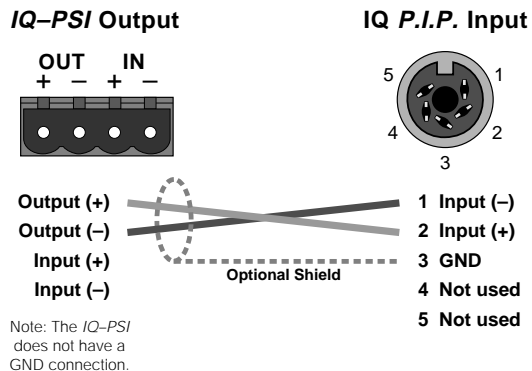

Fig. 3.6 *IQ-PSI* Output Connection to an *IQ P.I.P.* Input

the *IQ-PSI* connector to a 5-pin DIN input connector on an *IQ P.I.P.*

The *IQ* components in a Crown Bus loop are wired sequentially. The loop begins and ends with the *IQ-PSI*.

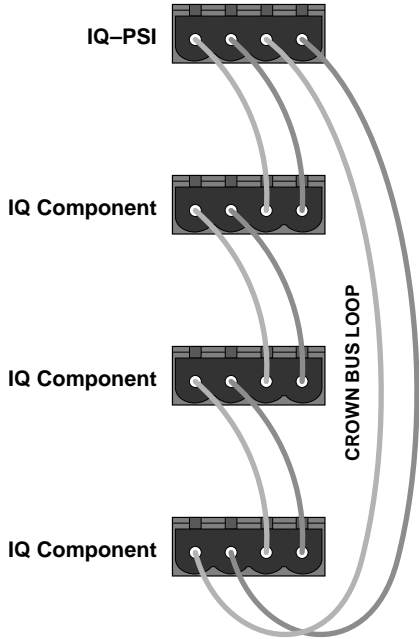

Fig. 3.7 Crown Bus Wiring "Loops" from the Output to the Input of Each IQ Component

The output of one *IQ* component "loops" to the input of the next and so on. This is shown below:

3.3 Connecting to a Host Computer

Most IBM® PCs have a serial or "com" port. This is actually an RS232 serial port. Because RS232 uses unbalanced signal wiring, it cannot be used for distances over 50 feet (15.2 m).



Connectors are numbered as they appear from the outside.

	PIN	(1, 4, 6, 9)	PIN	
Not used	2	Receive Data (RXD)	3	Transmit Data (TXD)
Receive Data (RXD)	3	Transmit Data (TXD)	2	Receive Data (RXD)
Transmit Data (TXD)	5	Signal Ground (GND)	5	Signal Ground (GND)
Signal Ground (GND)	7	Request to Send (RTS)	8	Clear to Send (CTS)
Request to Send (RTS)	8	Clear to Send (CTS)	7	Request to Send (RTS)

Fig. 3.8 RS232 Cable Wiring

The following illustration shows how the RS232 cable of the *IQ-PSI* is wired:

Note: A 9-pin to 25-pin adapter will be needed if the host computer you plan to use has a 25-pin connector instead of a 9-pin connector.

3.3.1 Setting the Baud Rate

Before communication can take place between the *IQ-*

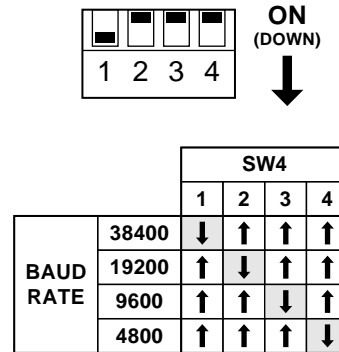

Fig. 3.9 Baud Rate Settings

PSI and a host computer, the baud rate must be set with the 4-segment DIP switch (SW4) located inside the battery compartment. (See Figure 3.9 below.) The highest baud rate possible should be used (typically 38,400).

Caution: Turn off the *IQ-PSI* before changing the baud rate setting.

Important: The baud rate of the *IQ-PSI* and the host computer must be the same. Any mismatch will prevent communication from taking place.

The communication parameters of the host computer are set by the *IQ* software. Please refer to the appropriate software manual for details.

Here are some important guidelines when configuring serial communication:

- Use the same communication standard at each end. The *IQ-PSI* supports only the RS232 standard. Other standards such as RS422 should not be used by the host computer. (Refer also to the appropriate *IQ* software manual.)
- Set the *IQ-PSI* and the host computer to the same baud rate.
- The *IQ-PSI* baud rate can be set as high as 38.4 K (38,400) baud. Use the highest baud rate possible, but be aware that the communication circuitry (UART) in some PCs cannot function over 9600 baud. We recommend that the host computer have a serial interface with a 16550-com-

patible UART.

- Do not use twisted-pair wire for RS232 cables because the unbalanced wiring of RS232 is susceptible to crosstalk. Instead use an untwisted cable or ribbon cable.
- If the host computer fails to communicate with the *IQ-PSI* and the baud rates are set the same, try reducing the baud rate of both the *IQ-PSI* and the computer.
- If communication problems persist, check the serial cable for damage.
- For further assistance, call Crown's Technical Support Group at 1-800-342-6939.

3.4 Connecting Auxiliary Devices

The auxiliary feature connector (AUX port) provides the means to interface the *IQ System* to non-IQ components. It can be used to turn another device on/off, send a signal to another component and receive a signal from another component.

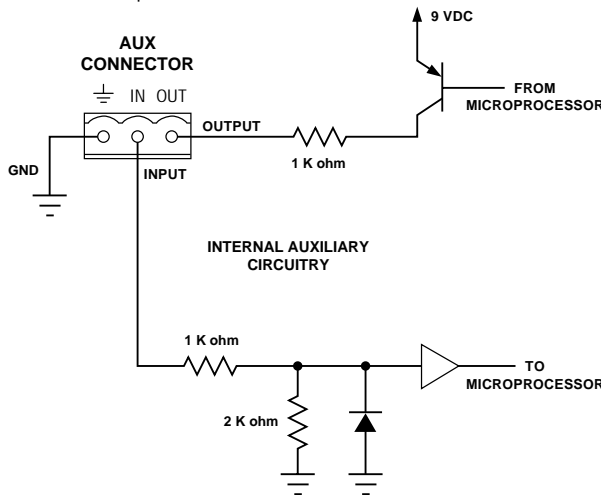

Fig. 3.10 The Internal AUX Port Circuit

The AUX connector is a 3-pin male "Euro-style" connector that accepts a screw-terminal plug (provided). The first and last pins are used to send a signal and first and second pins are used to receive a signal. The circuit diagram in Figure 3.10 shows the internal AUX circuit.

3.4.1 AUX Output

When the auxiliary feature is turned on by the *IQ System* software, +10 VDC is supplied across the ground and output pins for domestic units using an external power adapter (+9 VDC if battery power is used). For export

models this could be +8.5 to +15 VDC, depending on the specific power adapter provided by the user. A total of 10 milliamps of current is available. An internal 1.0 K ohm resistor protects against shorts.

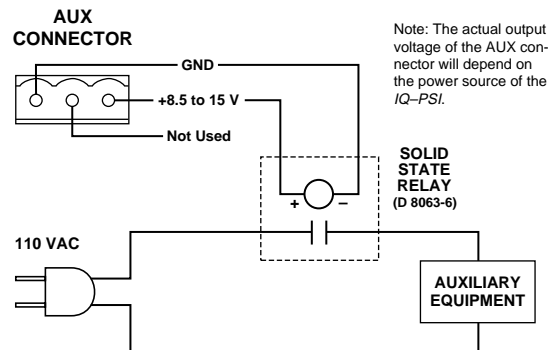

Fig. 3.11 A Sample AUX Output Circuit

There are many possible uses for the AUX output, limited only by imagination. For example, it can be used to turn on auxiliary cooling fans. To do this the AUX connector would be used to close a relay. The relay would then turn the fans on or off. This is shown in Figure 3.11 below.

Note: A Crown part number is provided in the above illustration for a suitable solid-state relay (D 8063-6). Contact your local Crown (or Amcron®) representative or the Crown factory Parts Department (219-294-8200) to order this relay.

By monitoring the operating condition of amplifiers with the *IQ System* software, the need for additional cooling will be apparent. The same software could then be used to turn on the appropriate AUX connector. (For more information about turning the auxiliary feature on/off, consult the *IQ software User's Manual*.)

In addition to the preceding examples, the AUX ports of more than one IQ component can be used to send binary codes to auxiliary equipment. For example, eight AUX ports can be used to send 8-bit binary codes to external equipment.

3.4.2 AUX Input

Depending on the IQ software being used, the AUX connector can sense the presence of an input signal across the ground and input pins. A 5 to 30 VDC signal at the input will be interpreted as a logic "high" and will be communicated to the Crown Bus where a host computer can act upon it. A signal less than 5 VDC is interpreted as a logic "low." *Note: A negative signal is interpreted as a logic low because the signal is internally clipped to protect the internal circuitry.*

4 Technical Information

The purpose of the *IQ-PSI* is to provide a means for the *IQ System* host computer to communicate with the *IQ* components on a Crown Bus loop. The pocket serial interface allows for different baud rates from the computer and uses the RS232 serial data standard. (The baud rate can be set from 4,800 to 38,400.)

The *IQ-PSI* functions as an interface when an active computer is connected to the RS232 port. If a computer is not present (or the computer is not on), the *IQ-PSI* will revert to the component mode.

Figure 4.1 shows a block diagram of the *IQ-PSI*. The microprocessor of the interface communicates with that of an *IQ* component over the 38,400 baud lines originating from its own internal UART. It communicates with a host computer via an external UART.

Data from the host computer arrives at the serial buffer at the user-selectable baud rate. The *IQ-PSI*

receives the message and retransmits it, if necessary, routing it to the appropriate component. If the message received is intended for the *IQ-PSI*, the unit takes appropriate action and responds with an acknowledgment to the host.

Response and echo messages received from the *IQ* loop are gathered at the loop input and sent out the RS232 transmitter back to the host PC at the user-determined baud rate.

The interface is also equipped with an auto reset feature, generated by the microprocessor, which provides both a reliable power-on reset and an automatic "warm" reset in case control is lost due to a noise pulse, etc.

An external +10 VDC power adapter is provided for connection to a 120 VAC mains (North America only). The unit can also operate for up to 1 hour with an alkaline 9-volt battery.

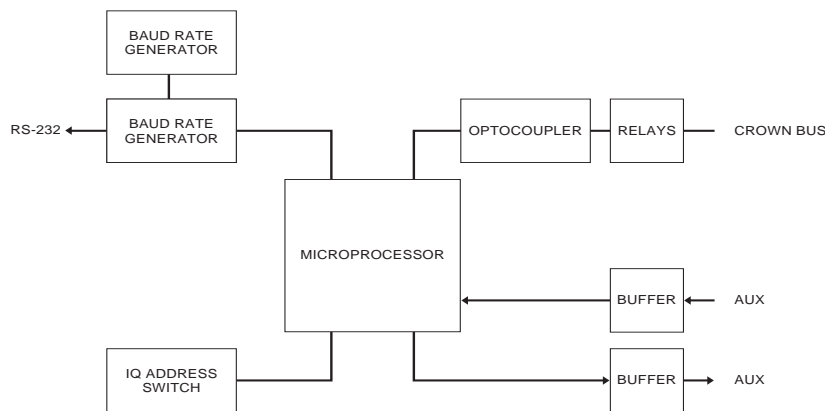

Fig. 4.1 IQ-PSI Circuit Block Diagram

5 Specifications

General

Internal Controls: A 4-segment DIP switch is used to configure the baud rate for communication with the host computer. An 8-segment DIP switch is used to set the IQ address of the interface. Both DIP switches are located inside the battery compartment.

External Controls: A two-position, Power On/Off switch.

Connectors: Crown Bus Input/Output: One 4-pin male "Euro-style" connector and a mating screw-terminal plug. AUX Port: One 3-pin male "Euro-style" connector and a mating screw-terminal plug. Computer: One female, 9-pin "D shell" connector attached to the unit via a 16-inch (41-cm) serial cable. External +10 VDC Power Input: One male coaxial DC power connector.

Indicators: A green Enable indicator is provided to show that the unit is turned on and receiving power. A yellow DSPI (Data Signal Presence Indicator) flashes when a valid IQ command is sent or received from the Crown Bus. It also provides a power-on battery indicator and can be forced to stay on to facilitate rapid troubleshooting of Crown Bus wiring. Both indicators are located on the top side of the unit.

Power Supply: An external power adapter is provided to transform standard 120 VAC, 60 Hz power to +10 VDC for the unit. In addition, the unit can be powered for about 1 hour with a 9-volt alkaline battery.

Finish: Molded black high-impact styrene.

Crown Bus Data Communication

Data Rate: 38.4 K baud.

Data Format: Serial, binary, asynchronous; 1 start bit; 1 stop bit; 8 data bits; no parity.

Interface Type: Optically isolated 20 milliamp serial loop.

Operation: Half duplex.

Intelligence: 8-bit microprocessor.

Transmission Distance: Variable from 200 to 3,000 feet (61 to 914 m), depending upon wire capacitance and baud rate. Typically 1,000 feet (305 m) using shielded twisted-pair wire, #26 AWG or larger. Can be extended with an IQ Repeater.

Host Computer Data Communication

Data Rate: 4800, 9600, 19200, or 38400 baud.

Data Format: Serial, binary, asynchronous; 1 start bit; 1 stop bit; 8 data bits; no parity.

Interface Type: RS232.

Operation: Half duplex.

Intelligence: 8 bit microprocessor.

Transmission Distance: 50 feet (15.2 m) maximum.

6 IQ Address Tables

This section contains lookup tables for every valid IQ address. The valid address are 1 to 250. **Do not use an address number higher than 250!** Addresses above 250 are reserved for special system use. And do not use address "0" (zero).

Remember: No two IQ components of the same type

which are connected to the same Crown Bus can have the same address.

To use the IQ address tables, simply find the address you want and set the IQ address switch of the *IQ-PSI* as shown. See Section 3.1 also.

IQ Address Switch									IQ Address Switch									IQ Address Switch								
IQ Address	1	2	3	4	5	6	7	8	IQ Address	1	2	3	4	5	6	7	8	IQ Address	1	2	3	4	5	6	7	8
0	OFF	OFF	OFF	OFF	OFF	OFF	OFF	OFF	42	OFF	ON	OFF	ON	OFF	ON	OFF	OFF	84	OFF	OFF	ON	OFF	ON	OFF	ON	OFF
1	ON	OFF	OFF	OFF	OFF	OFF	OFF	OFF	43	ON	ON	OFF	ON	OFF	ON	OFF	OFF	85	ON	OFF	ON	OFF	ON	OFF	ON	OFF
2	OFF	ON	OFF	OFF	OFF	OFF	OFF	OFF	44	OFF	OFF	ON	ON	OFF	ON	OFF	OFF	86	OFF	ON	ON	OFF	ON	OFF	ON	OFF
3	ON	ON	OFF	OFF	OFF	OFF	OFF	OFF	45	ON	OFF	ON	ON	OFF	ON	OFF	OFF	87	ON	ON	ON	OFF	ON	OFF	ON	OFF
4	OFF	OFF	ON	OFF	OFF	OFF	OFF	OFF	46	OFF	ON	ON	ON	OFF	ON	OFF	OFF	88	OFF	OFF	OFF	ON	ON	OFF	ON	OFF
5	ON	OFF	ON	OFF	OFF	OFF	OFF	OFF	47	ON	ON	ON	ON	OFF	ON	OFF	OFF	89	ON	OFF	OFF	ON	ON	OFF	ON	OFF
6	OFF	ON	ON	OFF	OFF	OFF	OFF	OFF	48	OFF	OFF	OFF	OFF	ON	ON	OFF	OFF	90	OFF	ON	OFF	ON	ON	OFF	ON	OFF
7	ON	ON	ON	OFF	OFF	OFF	OFF	OFF	49	ON	OFF	OFF	OFF	ON	ON	OFF	OFF	91	ON	ON	OFF	ON	ON	OFF	ON	OFF
8	OFF	OFF	OFF	ON	OFF	OFF	OFF	OFF	50	OFF	ON	OFF	OFF	ON	ON	OFF	OFF	92	OFF	OFF	ON	ON	ON	OFF	ON	OFF
9	ON	OFF	OFF	ON	OFF	OFF	OFF	OFF	51	ON	ON	OFF	OFF	ON	ON	OFF	OFF	93	ON	OFF	ON	ON	ON	OFF	ON	OFF
10	OFF	ON	OFF	ON	OFF	OFF	OFF	OFF	52	OFF	OFF	ON	OFF	ON	ON	OFF	OFF	94	OFF	ON	ON	ON	ON	OFF	ON	OFF
11	ON	ON	OFF	ON	OFF	OFF	OFF	OFF	53	ON	OFF	ON	OFF	ON	ON	OFF	OFF	95	ON	ON	ON	ON	ON	OFF	ON	OFF
12	OFF	OFF	ON	ON	OFF	OFF	OFF	OFF	54	OFF	ON	ON	OFF	ON	ON	OFF	OFF	96	OFF	OFF	OFF	OFF	OFF	ON	ON	OFF
13	ON	OFF	ON	ON	OFF	OFF	OFF	OFF	55	ON	ON	ON	OFF	ON	ON	OFF	OFF	97	ON	OFF	OFF	OFF	OFF	ON	ON	OFF
14	OFF	ON	ON	ON	OFF	OFF	OFF	OFF	56	OFF	ON	OFF	OFF	ON	ON	OFF	OFF	98	OFF	ON	OFF	OFF	OFF	ON	ON	OFF
15	ON	ON	ON	ON	OFF	OFF	OFF	OFF	57	ON	OFF	OFF	ON	ON	ON	OFF	OFF	99	ON	ON	OFF	OFF	OFF	ON	ON	OFF
16	OFF	OFF	OFF	OFF	ON	OFF	OFF	OFF	58	OFF	ON	OFF	ON	ON	ON	OFF	OFF	100	OFF	OFF	ON	OFF	OFF	ON	ON	OFF
17	ON	OFF	OFF	OFF	ON	OFF	OFF	OFF	59	ON	ON	OFF	ON	ON	ON	OFF	OFF	101	ON	OFF	ON	OFF	OFF	ON	ON	OFF
18	OFF	ON	OFF	OFF	ON	OFF	OFF	OFF	60	OFF	OFF	ON	ON	ON	ON	OFF	OFF	102	OFF	ON	ON	OFF	OFF	ON	ON	OFF
19	ON	ON	OFF	OFF	ON	OFF	OFF	OFF	61	ON	OFF	ON	ON	ON	ON	OFF	OFF	103	ON	ON	ON	OFF	OFF	ON	ON	OFF
20	OFF	OFF	ON	OFF	ON	OFF	OFF	OFF	62	OFF	ON	ON	ON	ON	ON	OFF	OFF	104	OFF	OFF	OFF	ON	OFF	ON	ON	OFF
21	ON	OFF	ON	OFF	ON	OFF	OFF	OFF	63	ON	ON	ON	ON	ON	ON	OFF	OFF	105	ON	OFF	OFF	ON	OFF	ON	ON	OFF
22	OFF	ON	ON	OFF	ON	OFF	OFF	OFF	64	OFF	OFF	OFF	OFF	OFF	OFF	ON	OFF	106	OFF	ON	OFF	ON	OFF	ON	ON	OFF
23	ON	ON	ON	OFF	ON	OFF	OFF	OFF	65	ON	OFF	OFF	OFF	OFF	OFF	ON	OFF	107	ON	ON	OFF	ON	OFF	ON	ON	OFF
24	OFF	OFF	OFF	ON	ON	OFF	OFF	OFF	66	OFF	ON	OFF	OFF	OFF	OFF	ON	OFF	108	OFF	OFF	ON	ON	OFF	ON	ON	OFF
25	ON	OFF	OFF	ON	ON	OFF	OFF	OFF	67	ON	ON	OFF	OFF	OFF	OFF	ON	OFF	109	ON	OFF	ON	ON	OFF	ON	ON	OFF
26	OFF	ON	OFF	ON	ON	OFF	OFF	OFF	68	OFF	OFF	ON	OFF	OFF	OFF	ON	OFF	110	OFF	ON	ON	ON	OFF	ON	ON	OFF
27	ON	ON	OFF	ON	ON	OFF	OFF	OFF	69	ON	OFF	ON	OFF	OFF	OFF	ON	OFF	111	ON	ON	ON	ON	OFF	ON	ON	OFF
28	OFF	OFF	ON	ON	ON	OFF	OFF	OFF	70	OFF	ON	ON	OFF	OFF	OFF	ON	OFF	112	OFF	OFF	OFF	OFF	ON	ON	ON	OFF
29	ON	OFF	ON	ON	ON	OFF	OFF	OFF	71	ON	ON	ON	OFF	OFF	OFF	ON	OFF	113	ON	OFF	OFF	OFF	ON	ON	ON	OFF
30	OFF	ON	ON	ON	ON	OFF	OFF	OFF	72	OFF	OFF	OFF	ON	OFF	OFF	ON	OFF	114	OFF	ON	OFF	OFF	ON	ON	ON	OFF
31	ON	ON	ON	ON	ON	OFF	OFF	OFF	73	ON	OFF	OFF	ON	OFF	OFF	ON	OFF	115	ON	ON	OFF	OFF	ON	ON	ON	OFF
32	OFF	OFF	OFF	OFF	OFF	ON	OFF	OFF	74	OFF	ON	OFF	ON	OFF	OFF	ON	OFF	116	OFF	OFF	ON	OFF	ON	ON	ON	OFF
33	ON	OFF	OFF	OFF	OFF	ON	OFF	OFF	75	ON	ON	OFF	ON	OFF	OFF	ON	OFF	117	ON	OFF	ON	OFF	ON	ON	ON	OFF
34	OFF	ON	OFF	OFF	OFF	ON	OFF	OFF	76	OFF	OFF	ON	ON	OFF	OFF	ON	OFF	118	OFF	ON	ON	OFF	ON	ON	ON	OFF
35	ON	ON	OFF	OFF	OFF	ON	OFF	OFF	77	ON	OFF	ON	ON	OFF	OFF	ON	OFF	119	ON	ON	ON	OFF	ON	ON	ON	OFF
36	OFF	OFF	ON	OFF	OFF	ON	OFF	OFF	78	OFF	ON	ON	ON	OFF	OFF	ON	OFF	120	OFF	OFF	OFF	ON	ON	ON	ON	OFF
37	ON	OFF	ON	OFF	OFF	ON	OFF	OFF	79	ON	ON	ON	ON	OFF	OFF	ON	OFF	121	ON	OFF	OFF	ON	ON	ON	ON	OFF
38	OFF	ON	ON	OFF	OFF	ON	OFF	OFF	80	OFF	OFF	OFF	OFF	ON	OFF	ON	OFF	122	OFF	ON	OFF	ON	ON	ON	ON	OFF
39	ON	ON	ON	OFF	OFF	ON	OFF	OFF	81	ON	OFF	OFF	OFF	ON	OFF	ON	OFF	123	ON	ON	OFF	ON	ON	ON	ON	OFF
40	OFF	OFF	OFF	ON	OFF	ON	OFF	OFF	82	OFF	ON	OFF	OFF	ON	OFF	ON	OFF	124	OFF	OFF	ON	ON	ON	ON	ON	OFF
41	ON	OFF	OFF	ON	OFF	ON	OFF	OFF	83	ON	ON	OFF	OFF	ON	OFF	ON	OFF	125	ON	OFF	ON	ON	ON	ON	ON	OFF

Fig. 6.1 IQ Address Switch (SW3) Settings from 0 to 125

IQ Address Switch									IQ Address Switch									IQ Address Switch								
IQ Address	1	2	3	4	5	6	7	8	IQ Address	1	2	3	4	5	6	7	8	IQ Address	1	2	3	4	5	6	7	8
126	OFF	ON	ON	ON	ON	ON	ON	OFF	168	OFF	OFF	OFF	ON	OFF	ON	OFF	ON	210	OFF	ON	OFF	OFF	ON	OFF	ON	ON
127	ON	ON	ON	ON	ON	ON	ON	OFF	169	ON	OFF	OFF	ON	OFF	ON	OFF	ON	211	ON	ON	OFF	OFF	ON	OFF	ON	ON
128	OFF	OFF	OFF	OFF	OFF	OFF	OFF	ON	170	OFF	ON	OFF	ON	OFF	ON	OFF	ON	212	OFF	OFF	ON	OFF	ON	OFF	ON	ON
129	ON	OFF	OFF	OFF	OFF	OFF	OFF	ON	171	ON	ON	OFF	ON	OFF	ON	OFF	ON	213	ON	OFF	ON	OFF	ON	OFF	ON	ON
130	OFF	ON	OFF	OFF	OFF	OFF	OFF	ON	172	OFF	OFF	ON	ON	OFF	ON	OFF	ON	214	OFF	ON	ON	OFF	ON	OFF	ON	ON
131	ON	ON	OFF	OFF	OFF	OFF	OFF	ON	173	ON	OFF	ON	ON	OFF	ON	OFF	ON	215	ON	ON	ON	OFF	ON	OFF	ON	ON
132	OFF	OFF	ON	OFF	OFF	OFF	OFF	ON	174	OFF	ON	ON	ON	OFF	ON	OFF	ON	216	OFF	OFF	OFF	ON	ON	OFF	ON	ON
133	ON	OFF	ON	OFF	OFF	OFF	OFF	ON	175	ON	ON	ON	ON	OFF	ON	OFF	ON	217	ON	OFF	OFF	ON	ON	OFF	ON	ON
134	OFF	ON	ON	OFF	OFF	OFF	OFF	ON	176	OFF	OFF	OFF	OFF	ON	ON	OFF	ON	218	OFF	ON	OFF	ON	ON	OFF	ON	ON
135	ON	ON	ON	OFF	OFF	OFF	OFF	ON	177	ON	OFF	OFF	OFF	ON	ON	OFF	ON	219	ON	ON	OFF	ON	ON	OFF	ON	ON
136	OFF	OFF	OFF	ON	OFF	OFF	OFF	ON	178	OFF	ON	OFF	OFF	ON	ON	OFF	ON	220	OFF	OFF	ON	ON	ON	OFF	ON	ON
137	ON	OFF	OFF	ON	OFF	OFF	OFF	ON	179	ON	ON	OFF	OFF	ON	ON	OFF	ON	221	ON	OFF	ON	ON	ON	OFF	ON	ON
138	OFF	ON	OFF	ON	OFF	OFF	OFF	ON	180	OFF	OFF	ON	OFF	ON	ON	OFF	ON	222	OFF	ON	ON	ON	ON	OFF	ON	ON
139	ON	ON	OFF	ON	OFF	OFF	OFF	ON	181	ON	OFF	ON	OFF	ON	ON	OFF	ON	223	ON	ON	ON	ON	ON	OFF	ON	ON
140	OFF	OFF	ON	ON	OFF	OFF	OFF	ON	182	OFF	ON	ON	OFF	ON	ON	OFF	ON	224	OFF	OFF	ON	OFF	OFF	ON	ON	ON
141	ON	OFF	ON	ON	OFF	OFF	OFF	ON	183	ON	ON	ON	OFF	ON	ON	OFF	ON	225	ON	OFF	OFF	OFF	OFF	ON	ON	ON
142	OFF	ON	ON	ON	OFF	OFF	OFF	ON	184	OFF	OFF	OFF	ON	ON	ON	OFF	ON	226	OFF	ON	OFF	OFF	OFF	ON	ON	ON
143	ON	ON	ON	ON	OFF	OFF	OFF	ON	185	ON	OFF	OFF	ON	ON	ON	OFF	ON	227	ON	ON	OFF	OFF	OFF	ON	ON	ON
144	OFF	OFF	OFF	OFF	ON	OFF	OFF	ON	186	OFF	ON	OFF	ON	ON	ON	OFF	ON	228	OFF	OFF	ON	OFF	OFF	ON	ON	ON
145	ON	OFF	OFF	OFF	ON	OFF	OFF	ON	187	ON	ON	OFF	ON	ON	ON	OFF	ON	229	ON	OFF	ON	OFF	OFF	ON	ON	ON
146	OFF	ON	OFF	OFF	ON	OFF	OFF	ON	188	OFF	OFF	ON	ON	ON	ON	OFF	ON	230	OFF	ON	ON	OFF	OFF	ON	ON	ON
147	ON	ON	OFF	OFF	ON	OFF	OFF	ON	189	ON	OFF	ON	ON	ON	ON	OFF	ON	231	ON	ON	ON	OFF	OFF	ON	ON	ON
148	OFF	OFF	ON	OFF	ON	OFF	OFF	ON	190	OFF	ON	ON	ON	ON	ON	OFF	ON	232	OFF	OFF	OFF	ON	OFF	ON	ON	ON
149	ON	OFF	ON	OFF	ON	OFF	OFF	ON	191	ON	ON	ON	ON	ON	ON	OFF	ON	233	ON	OFF	OFF	ON	OFF	ON	ON	ON
150	OFF	ON	ON	OFF	ON	OFF	OFF	ON	192	OFF	OFF	OFF	OFF	OFF	OFF	ON	ON	234	OFF	ON	OFF	ON	OFF	ON	ON	ON
151	ON	ON	ON	OFF	ON	OFF	OFF	ON	193	ON	OFF	OFF	OFF	OFF	OFF	ON	ON	235	ON	ON	OFF	ON	OFF	ON	ON	ON
152	OFF	OFF	OFF	ON	ON	OFF	OFF	ON	194	OFF	ON	OFF	OFF	OFF	OFF	ON	ON	236	OFF	OFF	ON	ON	OFF	ON	ON	ON
153	ON	OFF	OFF	ON	ON	OFF	OFF	ON	195	ON	ON	OFF	OFF	OFF	OFF	ON	ON	237	ON	OFF	ON	ON	OFF	ON	ON	ON
154	OFF	ON	OFF	ON	ON	OFF	OFF	ON	196	OFF	OFF	ON	OFF	OFF	OFF	ON	ON	238	OFF	ON	ON	ON	OFF	ON	ON	ON
155	ON	ON	OFF	ON	ON	OFF	OFF	ON	197	ON	OFF	ON	OFF	OFF	OFF	ON	ON	239	ON	ON	ON	ON	OFF	ON	ON	ON
156	OFF	OFF	ON	ON	ON	OFF	OFF	ON	198	OFF	ON	ON	OFF	OFF	OFF	ON	ON	240	OFF	OFF	OFF	OFF	ON	ON	ON	ON
157	ON	OFF	ON	ON	ON	OFF	OFF	ON	199	ON	ON	ON	OFF	OFF	OFF	ON	ON	241	ON	OFF	OFF	OFF	ON	ON	ON	ON
158	OFF	ON	ON	ON	ON	OFF	OFF	ON	200	OFF	OFF	OFF	ON	OFF	OFF	ON	ON	242	OFF	ON	OFF	OFF	ON	ON	ON	ON
159	ON	ON	ON	ON	ON	OFF	OFF	ON	201	ON	OFF	OFF	ON	OFF	OFF	ON	ON	243	ON	ON	OFF	OFF	ON	ON	ON	ON
160	OFF	OFF	OFF	OFF	OFF	ON	OFF	ON	202	OFF	ON	OFF	ON	OFF	OFF	ON	ON	244	OFF	OFF	ON	OFF	ON	ON	ON	ON
161	ON	OFF	OFF	OFF	OFF	ON	OFF	ON	203	ON	ON	OFF	ON	OFF	OFF	ON	ON	245	ON	OFF	ON	OFF	ON	ON	ON	ON
162	OFF	ON	OFF	OFF	OFF	ON	OFF	ON	204	OFF	OFF	ON	ON	OFF	OFF	ON	ON	246	OFF	ON	ON	OFF	ON	ON	ON	ON
163	ON	ON	OFF	OFF	OFF	ON	OFF	ON	205	ON	OFF	ON	ON	OFF	OFF	ON	ON	247	ON	ON	ON	OFF	ON	ON	ON	ON
164	OFF	OFF	ON	OFF	OFF	ON	OFF	ON	206	OFF	ON	ON	ON	OFF	OFF	ON	ON	248	OFF	OFF	OFF	ON	ON	ON	ON	ON
165	ON	OFF	ON	OFF	OFF	ON	OFF	ON	207	ON	ON	ON	ON	OFF	OFF	ON	ON	249	ON	OFF	OFF	ON	ON	ON	ON	ON
166	OFF	ON	ON	OFF	OFF	ON	OFF	ON	208	OFF	OFF	OFF	OFF	ON	OFF	ON	ON	250	OFF	ON	OFF	ON	ON	ON	ON	ON
167	ON	ON	ON	OFF	OFF	ON	OFF	ON	209	ON	OFF	OFF	OFF	ON	OFF	ON	ON									

Fig. 6.2 IQ Address Switch (SW3) Settings from 126 to 250

7 Service

This unit has very sophisticated circuitry which should only be serviced by a fully trained technician.

7.1 Worldwide Service

Service may be obtained from an authorized service center. (Contact your local Crown/Amcron representative or our office for a list of authorized service centers.) To obtain service, simply present the bill of sale as proof of purchase along with the defective unit to an authorized service center. They will handle the necessary paperwork and repair.

Remember to transport your unit in the original factory pack.

7.2 North American Service

Service may be obtained in one of two ways: from an authorized service center or from the factory. You may choose either. It is important that you have your copy of the bill of sale as your proof of purchase.

7.2.1 Service at a North American Service Center

This method usually saves the most time and effort. Simply present your bill of sale along with the defective unit to an authorized service center to obtain service. They will handle the necessary paperwork and repair. Remember to transport the unit in the original factory pack. A list of authorized service centers in your area can be obtained from our Technical Support Group.

7.2.2 Factory Service

To obtain factory service, fill out the **service information page** that follows and send it along with your proof of purchase and the defective unit to the Crown factory. For warranty service, we will pay for ground shipping both ways in the United States after receiving copies of the shipping receipts. Shipments should be sent "UPS ground." (If the unit is under warranty, you may send it C.O.D. for the cost of freight via UPS ground.) The factory will return it via UPS ground. Please contact us if other arrangements are required.

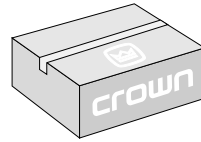

Always use the original factory pack to transport the unit.

Factory Service Shipping Instructions:

1. When sending a Crown product to the factory for service, be sure to fill out the service information form that follows and enclose it inside your unit's shipping pack. Do not send the service information form separately.
2. To ensure the safe transportation of your unit to the factory, ship it in an original factory packing container. If you don't have one, call or write Crown's Parts Department. With the exception of polyurethane or wooden crates, any other packing material will not be sufficient to withstand the stress of shipping. **Do not use loose, small size packing materials.**
3. Do not ship the unit in any kind of cabinet (wood or metal). Ignoring this warning may result in extensive damage to the unit and the cabinet. Accessories are not needed—do not send the instruction manual, cables and other hardware.

If you have any questions, please call or write the Crown Technical Support Group.

Crown Audio Division

Technical Support / Factory Service
Plant 2 SW, 1718 W. Mishawaka Rd., Elkhart,
Indiana 46517 U.S.A.

Telephone: 219-294-8200
800-342-6939 (North America,
Puerto Rico, and Virgin Islands only)

Fax: 219-294-8124 (Factory Service)
219-294-8301 (Tech Support)

Fax Back: 219-293-9200 (North America only)
800-294-4094 (North America only)
219-294-8100 (International)

Internet: <http://www.crownintl.com>

